



FLIP TARP SINGLE & DOUBLE UNDERBODY TRAILERS INSTALLATION INSTRUCTIONS



FLIP TARP TRAILER INSTALLATION

Congratulations on your purchase of a Mountain Flip Tarp Trailer system. With tarping systems for dump bodies, transfer trailers, scrap trailers, landscaping trucks and roll-offs, Mountain Tarp offers the most complete line of tarping systems and parts in the industry.

Note:

Please read through instructions for entire system and follow instructions thoroughly to ensure your system will work properly. It is important that you inspect your trailer and prepare it for installation by removing any sharp edges or any thing that will cause damage to your tarp.

For further technical assistance, contact our corporate headquarters at (800) 248-7717 or email us at sales@mountaintarp.com. For parts and service, visit us at one of our locations in Kentucky, Texas, or Ohio, or contact one of our many dealers nationwide. To learn more about Mountain Tarp and the products we offer, visit us online at www.mountaintarp.com.

WARNING:

- Never operate tarp system under power lines, this may cause injury due to electrocution.
- Never operate tarp system while moving.

MAINTENANCE

- Spray all bearings and sprocket chain with penetrating oil. “NO GREASE”
- Brush spring with steel brush weekly to remove dirt and spray with penetrating oil
- If you have a manual system, spray the sprocket chain once a week.
- Spray springs with a lubricating spray about once a week for the 4 bearings. The bearings come pre-packed with grease and do not need to be greased at all. If they are greased, the bearings will pick up dirt and grime from the road and the cases will burst

TABLE OF CONTENTS

Single Underbody Instructions

Step 1: Head Roller Assembly	3	Operating Instructions	9
Step 2: Underbody Assembly	4	Wiring Diagrams	10
Step 3: Under the Rail Hex Assembly - Trailers Under 30'	5	Parts Guide	11
Step 4: Over 30' Underbody Assembly	5		
Step 5: Frameless Trailers	5		
Step 6: Gear Box, Chain & Chain Guard	6-7		
Step 7: Contact Pads and Wire	7		
Step 8: Arms	8		
Step 9: Tarp	8		
Step 10: Crossover	9		

Double Underbody Instructions

Step 1: Mounting Roller Assembly to Bulkhead	12
Step 2: Underbody Assembly	12-13
Step 3: Underbody Assembly (Through the Rail)	13-14
Step 4: Arms	14-15

FLIP TARP TRAILER INSTALLATION

STEP 1: INSTALLING HEAD ROLLER BOX

1A:

Mounting the head roller braces to the front of the bulkhead, see figure 1.

The top of the brace should be 8" from top of bulkhead (Note: If roller box is taller than eight inches, lower braces so that top of roller box will be flush with top of bulkhead). If the front corner radius of trailer is 16" or less, the outside edge of the brace should be placed at beginning of the corner radius, see figure 1a. If the corner radius is greater than 16" the outside edge of the brace should be placed outside the beginning of the corner radius so that the outside edge of the brace is approximately 12" to 16" from the outside edge of the trailer, see figure 1b. When measurements are complete for brace placement, using 1/2" drill bit, drill holes in the bulkhead to match the holes in the braces. Next, using 1/2" x 1-1/2" hex bolts, 1/2" flat washers, and 1/2" lock nut, fasten the braces firmly to the bulkhead (Note: Roller braces should never be more than 16" from edge of trailer).

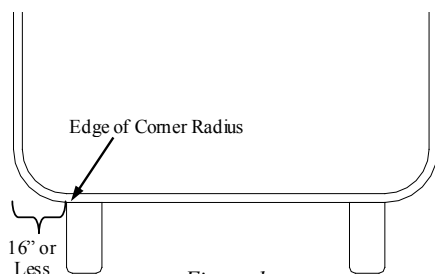

Figure 1a

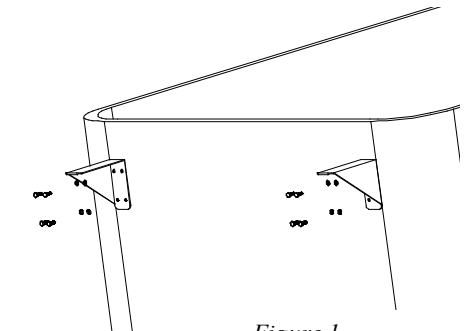

Figure 1

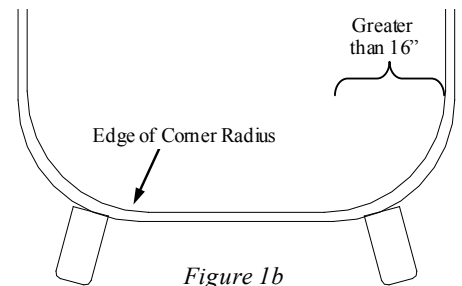

Figure 1b

1B:

Mounting the head roller box to the braces, see figure 2. Set the head roller box assembly on top of braces. Move the roller box so that the driver side edge is lined up with the driver side edge of the trailer, see figure 2a, next move the box so that the front of the box is nearly flush with the front edge of the braces. When desired position is achieved, clamp box in place, then using a 1/2" drill bit, drill holes through both, the braces, and the bottom of the roller box (there should be three holes for each brace, two in front and one in rear). When the desired roller box placement is achieved, using 1/2" x 1-1/2" hex bolts, 1/2" flat washers, and 1/2" lock nut, fasten the head roller box firmly to the braces. If front mount is not possible mount the roller box on top of the bulkhead, see figure 2b.

To mount the roller box on top, align the driver side of the box with the driver side of the trailer as seen in figure 2a, and place it as far forward as possible (flush with front of trailer). Then using a 1/2" drill bit drill holes through the bottom of the roller box and matching holes through the top rail, two holes on each side of trailer. Then, using 1/2" x 1-1/2" hex bolts, 1/2" flat washers, and 1/2" nuts, fasten the roller box to top of bulkhead.

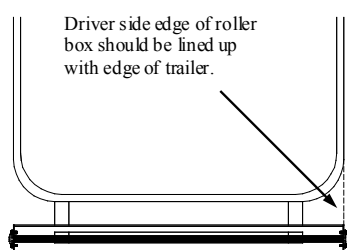

Figure 2a

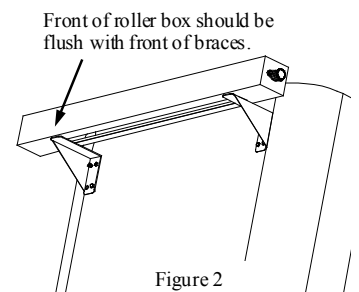

Figure 2

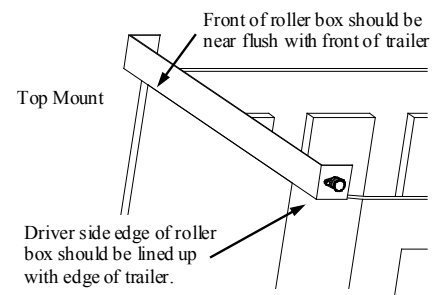

Figure 2b

FLIP TARP TRAILER INSTALLATION

STEP 2: INSTALLING UNDERBODY ASSEMBLY

2A:

Finding the placement for the underbody assembly (pivot point). See Figure 3. Find the center point of the trailer to determine placement for the underbody assembly. Using two tape measures, hook the end of one to the tarp axle and the end of the other to the top rear corner of the tailgate and measure toward the center at the bottom of the trailer. Where the tape measures cross at the same measurement is the center point of the system (Note: pivot point must be at least 3-1/2" from nearest horizontal standard, adjust forward to fall short of tailgate, adjust rearward to fall short of roller box). At the center point, measure up from the bottom of the bottom rail 1-3/4" (or appropriate distance see figure 3a), then cut a hole in the bottom rail with a 1-1/2" hole saw. This is the pivot point of the system.

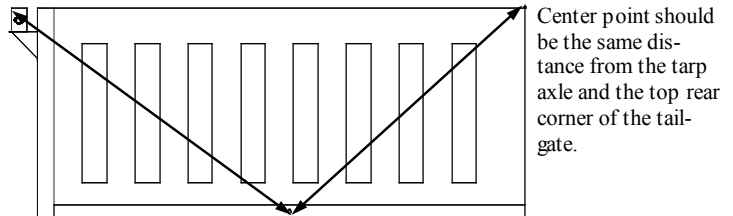

Figure 3

For height of pivot point, add 1-1/2" to this measurement (ex: if distance from bottom of bottom rail to bottom of horizontal standard is 1/4", pivot point will be 1-3/4" from bottom of bottom rail.

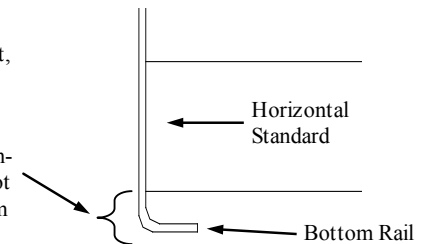
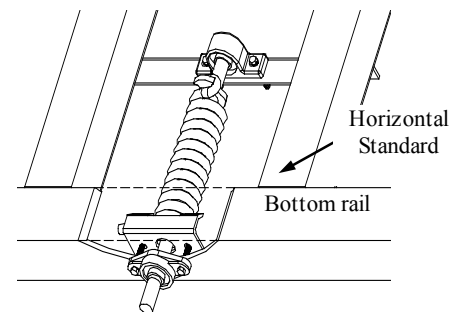

Figure 3a

2B:

Installing the spring assembly, see figure 4. Start by welding the spring support angle into place. Measure in from the outside of the bottom rail (the outside edge of the angle should be 13" from the outside edge of the bottom rail). Next hold the top of the angle against the bottom of the horizontal standards at 13" from the outside of the top rail and weld or bolt into place, see figure 4a. Then place the spring assembly by first using the nearest horizontal standard as a reference point. Measure to the center of the hole previously cut for the spring shaft, then measure the same distance from the same horizontal standard and mark the support angle at this point. Place the spring assembly putting the pillow block bearing on top of the angle and inserting the spring shaft out through the bottom rail. The center of the pillow block bearing should be placed at the mark on the angle, (this will make the spring shaft square with the bottom rail). Next align the outside edge of the pillow block bearing flush with the outside edge of the support angle and clamp into place. Using a 3/8" drill bit, drill holes in the support angle to match the holes in the pillow block bearing. Then use 3/8" x 1-1/2" hex bolts, 3/8" flat washers, and 3/8" nuts to fasten the bearing firmly to the angle.



Cut-away assembly view, **do not** cut bottom rail!!

The next step is to mount the flange bearing outside the bottom rail. Slide the flange bearing onto the end of the spring shaft and center the bore hole in the bearing with the previously cut hole in the bottom rail of the trailer. Using a 3/8" drill bit, drill holes in the bottom rail to match the bolt holes in the bearing. Then use 3/8" x 2" hex bolts, 3/8" flat washers, and 3/8" nuts to fasten the bearing firmly to the bottom rail of the trailer (Note: when inserting bolts, hold spring retainer against inside of the rail and put bolt through bearing, rail and spring retainer before the washer and nut. The retaining wings on the spring retainer should be on top). Next make sure the spring is pulled firmly against the spring retainer and the clip on the spring shaft is centered in the "U" shaped portion of the spring, then tighten allen screws firmly on the bearing to secure it.

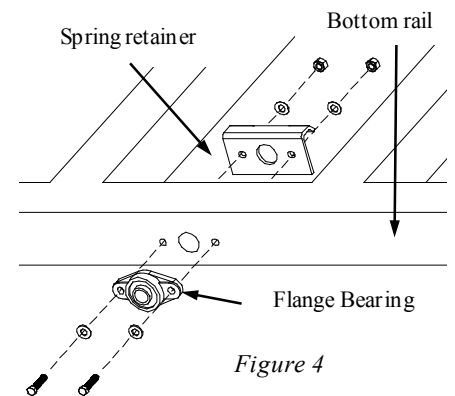

Figure 4

FLIP TARP TRAILER INSTALLATION

STEP 3: INSTALLING UNDER-THE-RAIL HEX ASSEMBLY FOR TRAILERS UNDER 30'

3A:

Assembling the spring, shaft, spring retainer, and spring plate, see figure 4b.

3B:

Installing the spring and shaft assembly, see figure 4c. Hold previously assembled spring and shaft under the body so that the top of the spring retainer is against the bottom of the bottom rail and the spring plate is on the outside of the bottom rail. Using a 1/2" drill bit, drill holes in bottom rail to match holes in spring plate. Next using 1/2"x 1-1/2" hex bolts, 1/2" flat washers, and 1/2" nuts, fasten assembly to bottom rail (Note: If spring and shaft assembly interferes with obstructions under the body, it may be necessary to dismantle spring plate and mount through the rail. See *Instructions for Installing Underbody Assembly*. Follow the instructions on page 4, except the pillow block bearing and angle will not be needed).

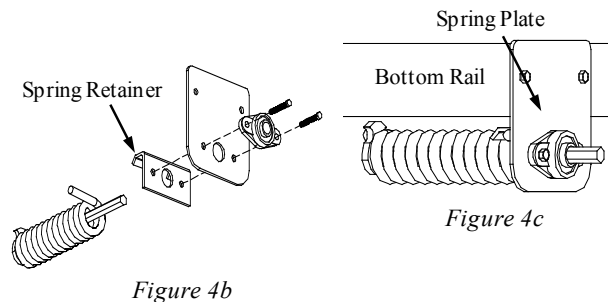
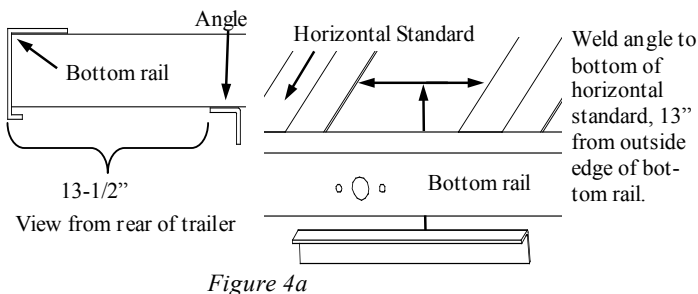

STEP 4: INSTALLING UNDER-THE-RAIL ROUND ASSEMBLY

4A:

First, connect the spring and shaft assembly to the spring plate, see figure 4b.

4B:

Installing the spring and shaft assembly, Find the pivot point of the system, then install a piece of 2"x2" steel channel following the instructions on the previous page for installing the 2"x2"x20" angle. Mount pillow block bearing upside down to the bottom of the channel with the center of the bearing at the center point of the system previously found. Next install the spring and shaft assembly by inserting the inside end of the spring shaft into the pillow block bearing. Hold the assembly so that the center of the spring plate is at the center point of the system and on the outside of the bottom rail (Note: spring and shaft need to be level with the trailer for proper system function). With the spring and shaft level with the trailer, using a 1/2" drill bit, drill holes in the bottom rail to match the holes in the spring plate. Then, using 1/2"x1-1/2" hex bolts, 1/2" flat washers, and 1/2" nuts, fasten spring plate to the bottom rail.

STEP 5: INSTALLING UNDERBODY ASSEMBLY FOR FRAMELESS TRAILERS

5A:

Installing the spring and shaft assembly, see figure 4e. First, install angle 13" from inside of interior rail. Then mount the spring and shaft assembly with the pillow block bearing on top of the angle. The spring retainer should be inside the interior rail with one flange bearing outside the interior rail and one flange bearing outside the exterior bottom rail. All other steps are same as "Installing spring assembly" on the previous page.

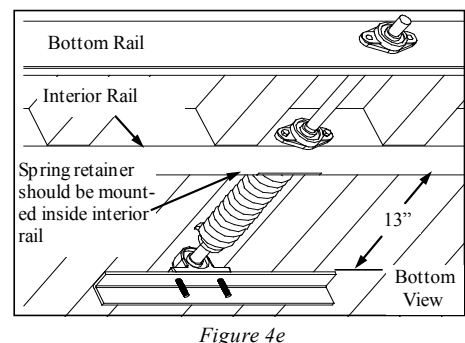

FLIP TARP TRAILER INSTALLATION

STEP 6: INSTALLING GEAR BOX, CHAIN & CHAIN GUARD (MANUAL ONLY)

6A:

Installing the gear box assembly (Q). The gear box must be installed at the very front of the bottom rail on the driver side. First find the most convenient place as close to the front of the trailer as possible, (Note: it may be necessary to fabricate a mount if no flush mount fender is available) and clamp the gear box in place (Note: it may be necessary to angle the gear box so that its top is pointing directly at the sprocket on the end of the head roller box assembly).

Once placed, lower the gear box until the bottom of the box is resting on the bottom rail or applicable mounting structure, then using a 3/8" drill bit, drill holes in the rail at the very top of the slots in the flange at the bottom of the gear box, *see figure 5*. These slots will allow you to adjust the gear box to either change the angle or to tighten the chain once installation is complete. Then use 3/8"x1-1/2" hex bolts, 3/8" flat washers, and 3/8" nuts to secure the gear box to the rail without tightening completely.

6B:

Installing the sprocket chain (S). Slide the gear box up so that the mounting bolts are at the bottom of the slots in the mounting bracket to find the chain length. Measure from the top of the sprocket on the roller box assembly to the bottom of the gear box, double this measurement and subtract 2", *see figure 6*. Cut the chain at this length with proper cutting tools, wrap the chain around the sprocket on the gear box and the sprocket on the head roller box, and connect the ends using the master link provided (Note: if necessary, loosen bolts connecting the gear box to the bottom rail and adjust to create or eliminate slack, then retighten bolts).

6C:

Installing the chain guard (T). After installing the chain, connect the chain guard to the gear box and the head roller box (Note: to install the chain guard with the chain already in place, cut a slot in the bracket on the back of the chain guard, otherwise the chain must be removed prior to installing the chain guard, *see figure 7b*). To find the proper length, measure from the bottom of the bearing on the outside of the head roller box to the top of the metal plate on the back of the gear box, *see figure 7*.

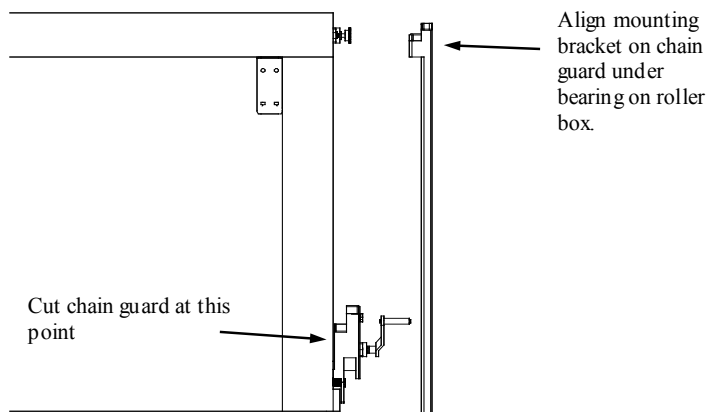
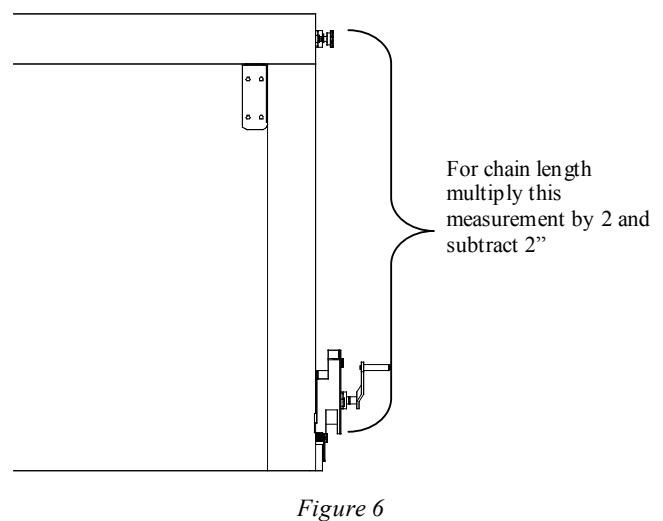
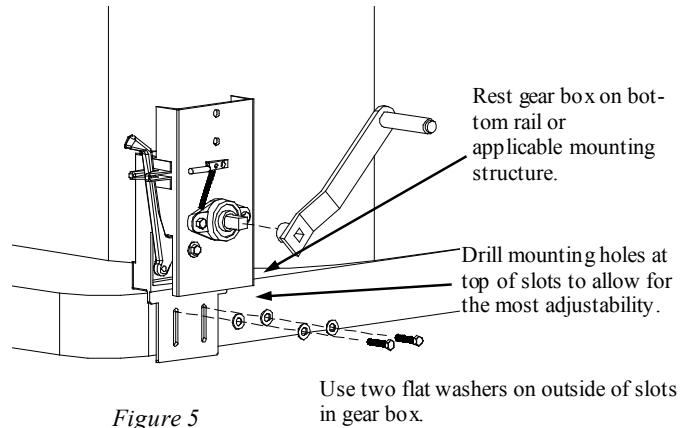

FLIP TARP TRAILER INSTALLATION

STEP 6: INSTALLING GEAR BOX, CHAIN & CHAIN GUARD CONT. (MANUAL ONLY)

6C:

After cutting the guard to the proper length, use a 3/8" drill bit and drill two holes through the chain guard to match the holes on the gear box. Then drill two 3/8" holes through the mounting plate on the rear of the chain guard and the end plate on the head roller box, see figure 7a. Use 3/8"x1" carriage bolts, 3/8" flat washers, 3/8" lock washers, and 3/8" nuts fasten the chain guard to the gear box. Then use 3/8"x1-1/4" carriage bolts, 3/8" flat washers, 3/8" lock washers, and 3/8" nuts to fasten the chain guard to the head roller box. When the gear box, chain guard, and head roller box are firmly connected and in the desired position, firmly tighten the bolts mounting the gear box to the bottom rail.

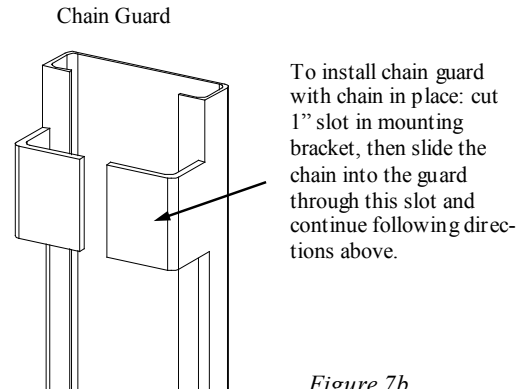
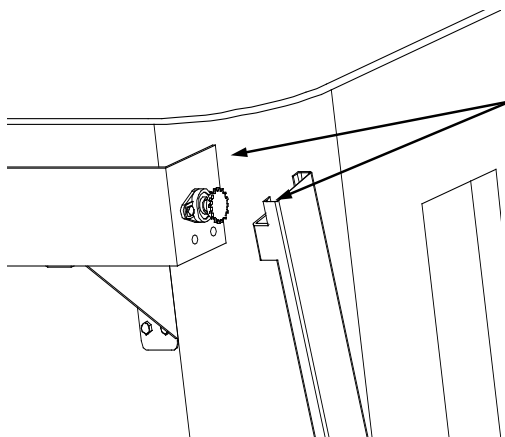

Figure 7b



To mount chain guard to head roller box, drill holes through both the mounting bracket on the chain guard and the end plate on the roller box.

Figure 7a

STEP 7: INSTALLING CONTACT PADS AND WIRE

7A:

For a framed trailer, first put contacts close to hydraulic line, then weld to the trailer. Once you have them securely welded in place, then weld on the steel. Push the steel contact up so that it compresses the springs approximately 1/2". With a 1-1/4" hole saw, put one hole behind the roller box in the radius and a hole under the bottom of the trailer in radius. This will let the wire drop out of the bottom of the trailer.

Place additional holes where the main front standard is on the bottom of the trailer, another on the front of the trailer where the aluminum contact is located, and another 1/2" from the contact. Then hook all of the connections up and run a piece of wire with the hydraulic line. Take this wire to the side with the steel and put the quick connect on the end of the wire.

FLIP TARP TRAILER INSTALLATION

STEP 8: CONNECTING THE ARMS

8A:

Connecting the arms (P) to the spring shaft. Determine the length the arms need to be before connecting them by measuring from the center of the spring shaft to the rear of the tailgate and subtracting 4". This will allow for the legs on the crossover (Note: this method of measurement is used if the pivot point of the system is at or less than 7" from the center of the trailer. If this measurement is greater than 7", then measure from the center of the spring shaft to the center of the tarp axle on the roller box assembly and subtract 4". This will cause the system to fall just short of the rear of the tailgate), *see figure 8*. Once the proper length is determined, cut the arms and scrap the remaining material.

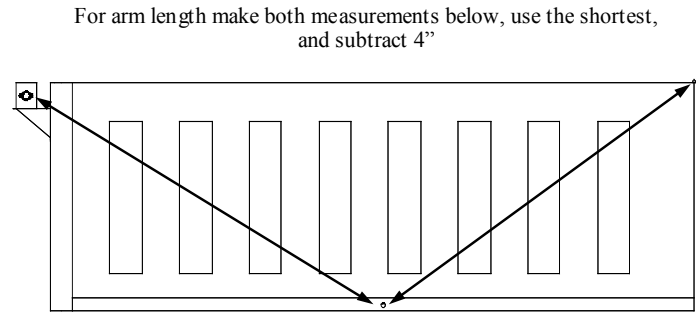
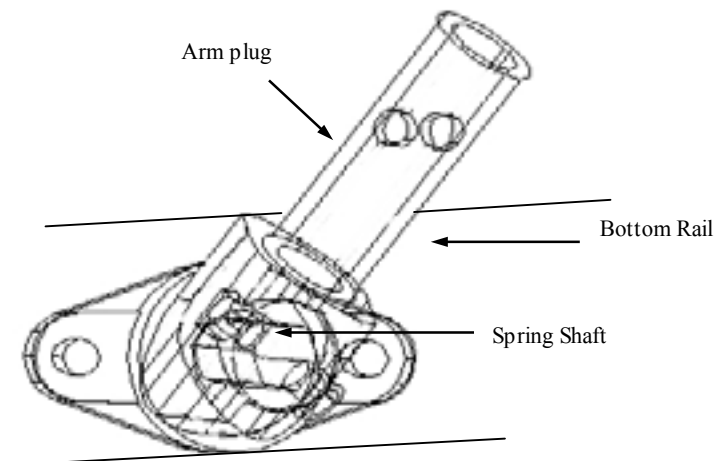

Figure 8

Next connect the arms to the spring shaft, *see figure 8a*. Slide the arm connector onto the shaft and slide the arm onto the pipe on the arm connector until it is against the plug on the connector (Note: the arm and connector should be pointing toward the rear of the trailer with the end of the arms resting on the ground). Then use a 3/8" drill bit to drill a hole through the arm and the pipe on the connector and fasten with a 3/8"x2-1/2" hex bolt, 3/8" flat washers, and a 3/8" lock nut.

Once the arm is bolted to the arm connector, find the proper spacing between the arms and the trailer. With the end of the arms resting on the ground, adjust them so that there is 1" between the arm connector and the flange bearing on the spring and shaft assembly and 6" between the arms and the tires on the trailer. Make sure the cold roll (spring shaft) is turned until the cold roll clip is against the inside of the "U" shaped bend in the spring (Note: when putting tension on the springs, use the following formula: trailers up to 28' turn 1 hour, trailers from 29' to 34' turn three hours, trailers from 35' to 37' turn five hours). When placing the hex arm connector, put the cold roll in place before putting the connector slightly askew from being horizontal with the trailer. This will give the proper tension on the spring (Note: if trailer is smaller than 30', the connector will need to be placed slightly further back to place less tension on the spring).



FLIP TARP TRAILER INSTALLATION

STEP 9: INSTALLING THE TARP

9A:

Connecting the tarp to the tarp axle, see *Figure 9*. Attach the tarp to the roller bar with the 3/8" x 3/4" hex bolts and washers provided as shown in *figure 9*.

9B:

Connecting the tarp to the crossover. To attach the tarp to the crossover simply thread the crossover through the pocket at the end of the tarp, (Note: it may be helpful to spray a lubricating oil into the pocket on the tarp before threading). Then, using the two hose clamps provided, secure the tarp to the crossover (Notes: the outside edge of the tarp should be 12" from the outside of the crossover, see *figure 9a*. You will need to cut small slits in the pocket of the tarp to get the hose clamps around the crossover).

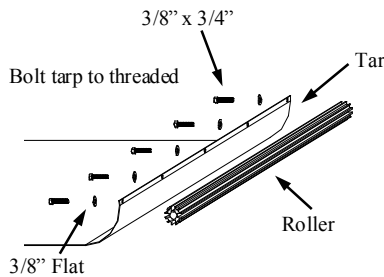

Figure 9

Note: When bolting the tarp to the roller bar, the end bolts on each side should be 5" from the end of the roller bar. The remaining bolts should be spaced evenly across the roller bar.

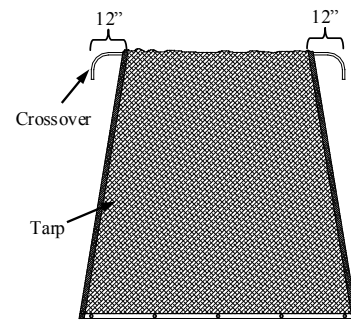

Figure 9a

STEP 9: INSTALLING THE CROSSOVER

10A:

Connecting the crossover to the arms. Using a ladder, lift the arms up to the top of the tailgate, with the tarp attached, slide the legs of the crossover into the end of the arm on each side of the trailer. Drill a hole through the arm and crossover leg with a 3/8" drill bit. Use 3/8" x 2-1/2" hex bolts, 3/8" flat washers, and 3/8" lock nuts to secure the crossover to the arm.

Repeat steps 1 through 9 on the other side.

FLIP TARP OPERATING INSTRUCTIONS

Covering the load:

1. Turn the crank handle counter clockwise just enough to relieve the pressure on the locking mechanism.
2. With brake applied, turn the clicker handle to 12 o'clock.
3. **REMOVE THE CRANK HANDLE.**
4. Open the gate latch to release the brake handle.
5. Gently release the brake.

The tarp should begin to flip. You can stop the system at any time by simply applying the break.

Uncovering the load:

1. Open the gate latch to release the brake handle.
2. Attach the crank handle to the gear box.
3. Turn counter clockwise.

This will roll the tarp up. You can stop at any time and the locking mechanism will hold the system in place. Stop cranking when the tarp is completely rolled up.

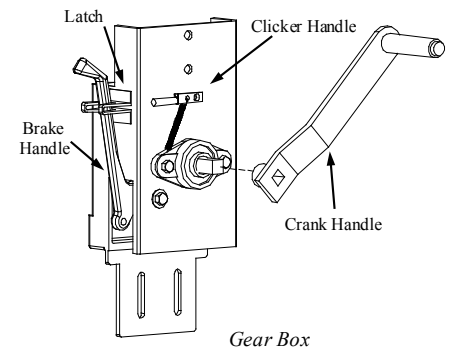

Warning: Do not release brake without **REMOVING THE CRANK HANDLE**. Do not release handle unless ratchet pawl is properly engaged. Do not disengage ratchet pawl unless tension is applied to handle. Failure to observe these warnings will cause handle to turn out of control and could cause personal injury.

FLIP TARP TRAILER INSTALLATION

WIRING DIAGRAM FOR ELECTRIC OPTION

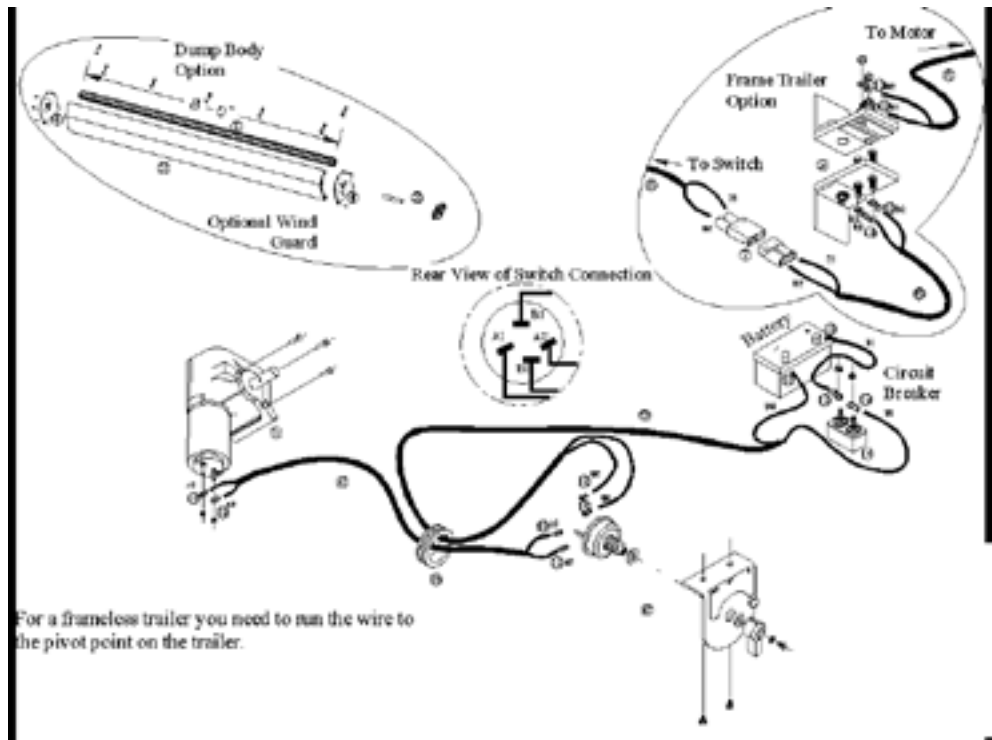

NEW WIRING DIAGRAM FOR ROCKER SWITCH

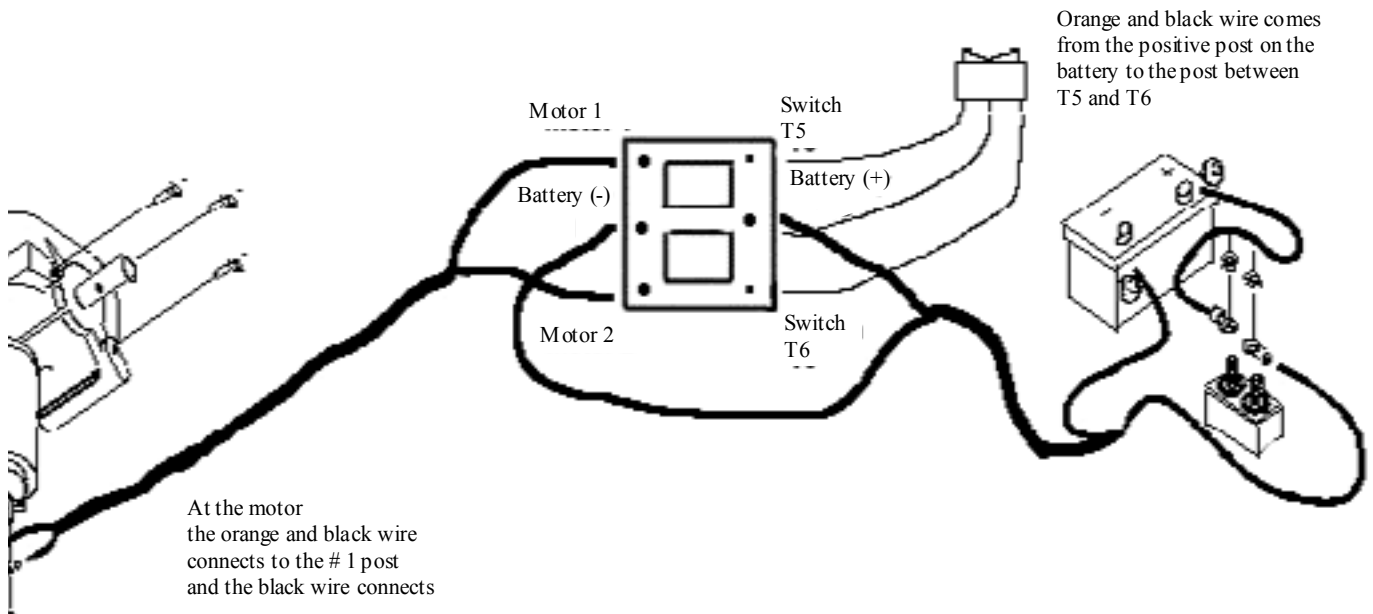

PARTS FOR MANUAL FLIP TARP TRAINER INSTALLATION

Head Roller Box, Gear Box, and Chain Guard also available in diamond tread plate.

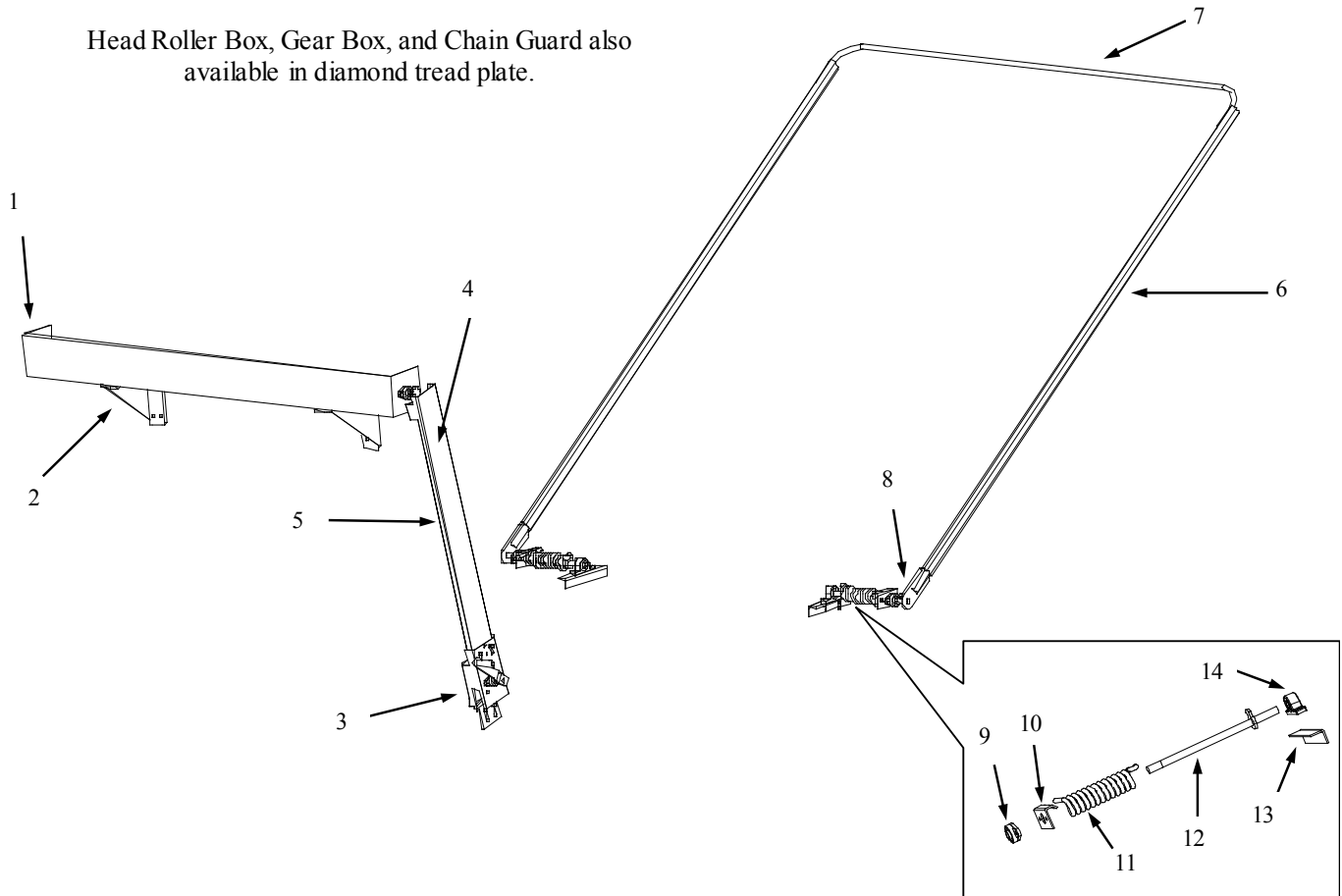

Des. #	Description	Part #	Des. #	Description	Part #
1	Head Roller Box Assembly (96")	K0101	7	Crossover (102")	K0422
1	Head Roller Box Assembly (102")	K0102	8	Arm Connector	K0415
2	Head Roller Brace (Driver Side)	K0120	9	Flange Bearing	K0515
2	Head Roller Brace (Passenger Side)	K0120R	19	Spring Retainer	K0196
3	Gear Box Assembly	KS6340	11	Spring (Driver Side)	K0501
4	Chain Guard	K0201	11	Spring (Passenger Side)	K0502
5	Sprocket Chain (16' Piece)	K0220	12	Cold Roll W/Clip (Spring Shaft) 19"	K0522
6	Arm (16')	K0411	13	2" x 2" x 20" Angle	K0531
7	Crossover (96")	K0420	14	Pillow Block Bearing	K0520

FLIP TARP TRAILER DOUBLE BODY INSTALLATION

STEP 1: MOUNTING THE ROLLER ASSEMBLY TO THE BULKHEAD

1A:
Installing the Roller Assembly to the Bulkhead, see figure 2. (Note: To mount the roller assembly, you will need the assistance of a second person). First, make a mark at the center and four inches down from the top of the bulkhead, then, make a mark four inches down and three inches inside the radius on each side of the bulkhead, then, make a mark half way between the center mark and the mark on each side. Next, using a 1/2" drill bit, drill a hole in the bulkhead at each mark. With the holes drilled, slide five bolts into the slot on the rear of the roller assembly K-Bar and line them up with each of the corresponding hole in the bulkhead. Then, fasten the roller assembly to the bulkhead using the bolts, nuts and washers provided, see figure 2a.

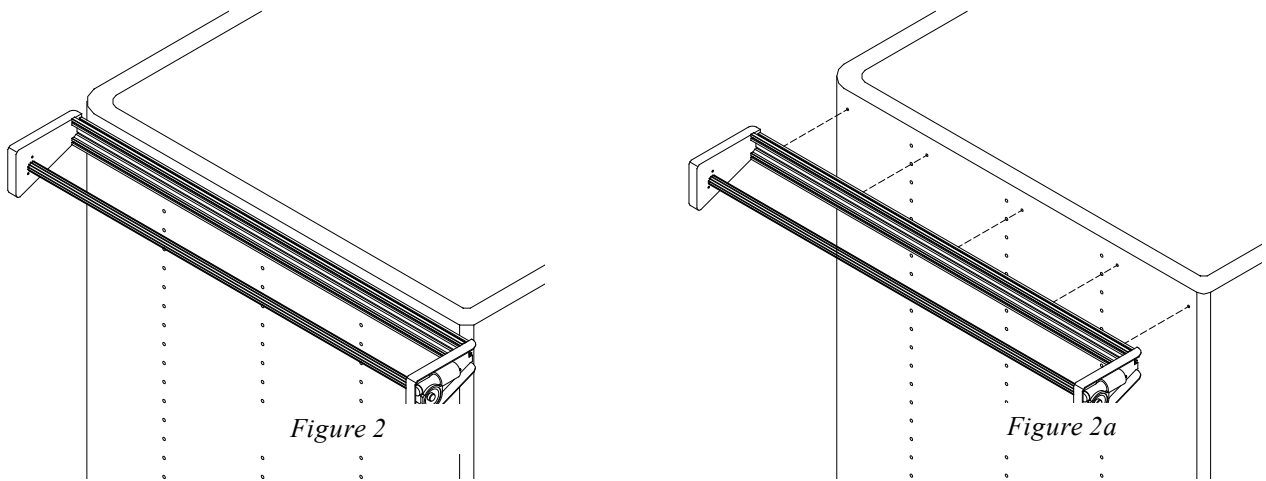

STEP 2: INSTALLING THE UNDERBODY ASSEMBLY

2A:
Finding the placement for the underbody assembly (pivot point). See Figure 3. To find the placement for the underbody assembly you must find the center (Pivot Point) of the trailer. Using two tape measures, hook the end of one to the tarp axle and the end of the other to the very top rear corner of the tailgate and measure toward the center at the bottom of the trailer. At the distance where the tape measures cross reading the same measurement is the pivot point of the system.

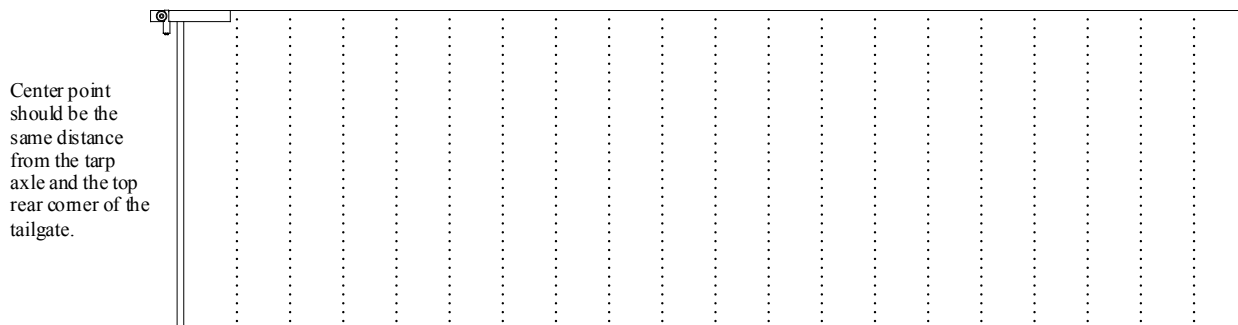

Figure 3

PARTS FOR MANUAL FLIP TARP TRAINER INSTALLATION

STEP 2: INSTALLING THE UNDERBODY ASSEMBLY CONT.

2B:

Installing the underbody assembly for under the rail applications, see figure 4. The underbody assembly for under the rail application should be pre-assembled and ready to mount. First, hold the assembly to the bottom of the trailer with the front spring directly aligned with the pivot point mark on the trailer and the top of the housing frame against the bottom of the trailer and make a mark on the trailer at each of the five mounting holes on the underbody housing face plate, see figure 4a. Next, remove the assembly and using a 1/2" drill bit, drill a hole at each of the five marks on the trailer. Replace the assembly and using five 1/2" x 1 1/2" hex bolts nuts and washers, secure the assembly to the trailer. Repeat this step for the opposite side of the trailer. After the assemblies are in place, push up on the inside portion of the underbody housing and using 2" x 2" x 2" piece of angle as a brace, weld the assembly to the horizontal standard closest to the center of the housing, see figure 4b.

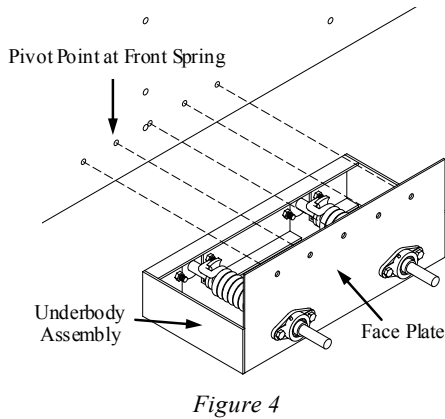

Figure 4

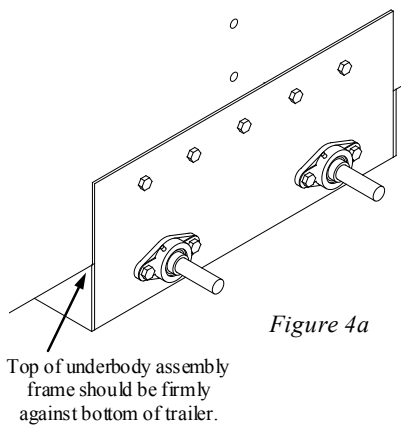

Figure 4a

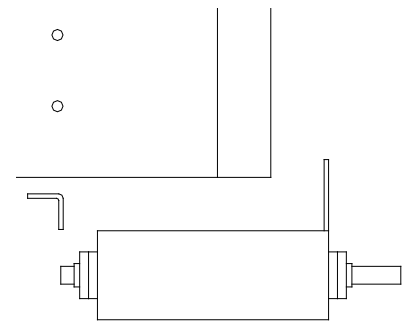

Figure 4b

STEP 3: INSTALLING THE UNDERBODY ASSEMBLY (THROUGH THE RAIL)

3A:

Installing the underbody assembly thru the rail application, see figure 5. With the pivot point previously determined, begin by drilling the bearing holes in the bottom of the trailer. First measure up from the bottom of the trailer 2-1/2" at the exact location of the pivot point and make a mark. Then from this mark, measure 14" toward the rear of the trailer and make a mark. This is where each of the two spring assemblies will be located. Next, using a 1-1/2" hole saw, drill a hole in the trailer at each of the two marks. Hold one of the flange bearings provided up to each of the two 1-1/2" holes with the center of the bearing at the center of the hole. Using a 3/8" drill bit, drill a hole in the trailer to match the two mounting holes in the bearing. Secure each of the two bearings to the trailer with 3/8"x1-1/2" hex bolt, nuts and washers. Repeat the previous steps and drill holes through the interior rail to match the holes drilled in the outside of the trailer (Note: make certain the holes on the interior rail are directly opposite the holes on the outside of the trailer so that the spring assembly is perfectly square with the trailer).

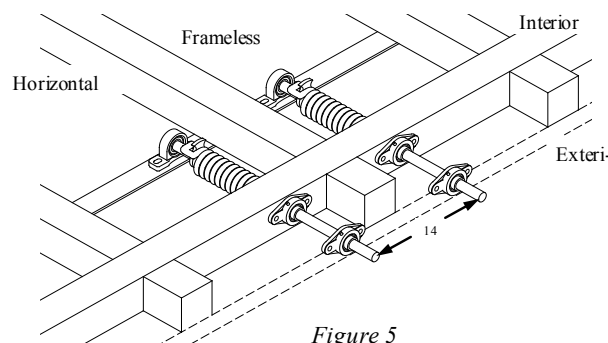

Figure 5

FLIP TARP TRAILER DOUBLE BODY INSTALLATION

STEP 3: INSTALLING THE UNDERBODY ASSEMBLY (THROUGH THE RAIL) CONT.

3B:

After drilling the holes completely through the interior rail, hold a flange bearing on the outside of the rail while at the same time holding the spring retainer to the inside of the interior rail. Then slide a 3/8"x4" hex bolt into each of the two mounting holes on the bearing proceeding through the interior rail and out through the matching holes in the spring retainer on the inside of the rail, *see figure 5a* (Note: the flange on the spring retainer should be on top). Secure the flange bearing and the spring retainer to the interior rail using the 3/8" nuts and washers provided. Repeat these steps to install the other bearing and spring retainer for the back-up spring assembly.

Next weld the 2"x2" angle provided to the bottom of the horizontal rails with the outside edge of the angle 13" from the inside edge of the interior rail, *see figure 5b*. After welding the angle in place, install the pillow block bearing on top of the angle so that the hole in the pillow block bearing is directly in line with the holes in the two previously installed flange bearings. To install the pillow block bearing, drill a 3/8" hole through the angle to match each of the two mounting holes in the bearing and secure it to the angle using two 3/8"x1-1/2" hex bolt, nuts and washers. Slide the cold roll into the spring so that the clip on the cold roll is resting inside the "U" shaped bend on the end of the spring. Then slide the end of the cold roll opposite the clip into the hole in the spring retainer and out through the interior rail, through the flange bearing, the wall of the trailer and then the other flange bearing on the outside of the trailer.

Place the other end of the cold roll into the pillow block bearing until the end of the cold roll is flush with the inside of the flange bearing (Note: it may be necessary to loosen or remove the pillow block bearing in order to get the cold roll and spring into place. Also, to determine the correct spring for its respective side of the trailer, the open portion of the "U" shaped bend in the spring should be toward the rear of the trailer). Finally, pull out on the cold roll so that the spring is firmly against the spring retainer inside the interior rail and tighten the set screws on all bearings. Follow these steps for both the primary and back-up spring assembly on each side of the trailer.

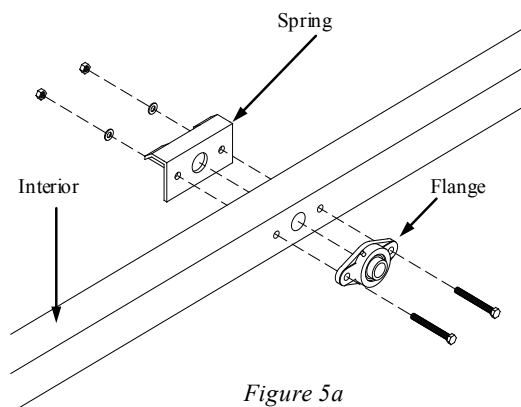
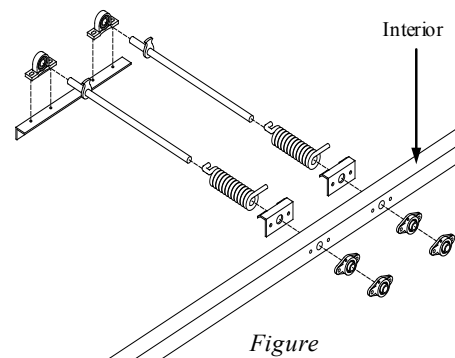

Figure 5a



Figure

STEP 4: CONNECTING THE ARMS

4A:

Connecting the arms to the spring shaft. Before connecting the arms you must first determine the length they need to be. To do this, measure from the center of the front spring shaft to the top rear of the tailgate and subtract 25" for double underbodies. This will allow for the legs on the crossover and the arm connector (Note: this method of measurement is used if the pivot point of the system is at or less than 7" from the center of the trailer. If this measurement is greater than 7" then measure from the center of the spring shaft to the center of the tarp axle on the roller box assembly and subtract 25". This will cause the system to fall just short of the rear of the tailgate). When the proper length is achieved, cut the arms and scrap the remaining material.

FLIP TARP TRAILER DOUBLE BODY INSTALLATION

STEP 4: CONNECTING THE ARMS CONT.

4A:

Connecting the arms to the spring shaft (continued). After the arms are cut, the next step is to connect them to the spring shaft, *see figure 6a*. First slide the arm connector onto the front spring shaft and slide the arm onto the pipe on the arm connector (Note: the arm and connector should be pointing toward the rear of the trailer with the end of the arms resting on the ground). Slide the arm until it is against the plug on the connector, then use a 3/8" drill bit to drill a hole through the arm and the pipe on the connector and fasten using a 3/8"x2-1/2" hex bolt, 3/8" flat washers, and a 3/8" nut.

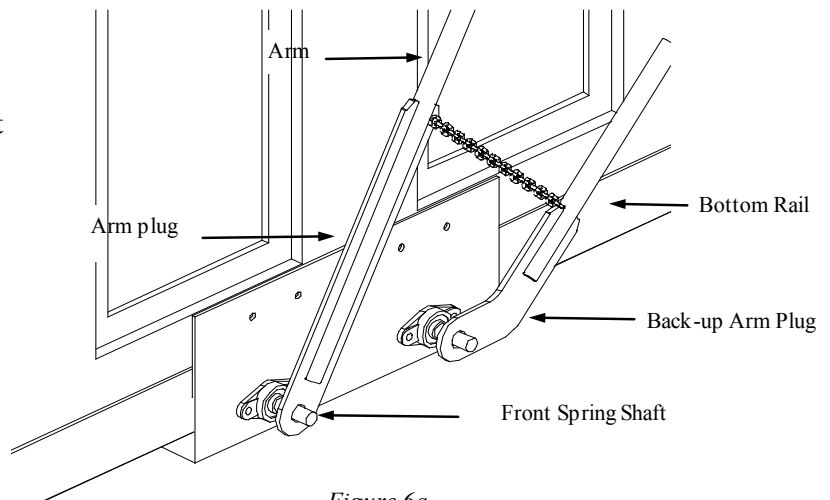

After bolting the arm to the arm connector, the next step is to get the proper spacing between the arms and the trailer. With the end of the arms resting on the ground, adjust them so there is 1" between the arm connector and the front flange bearing on the spring and shaft assembly and 6" between the arms and the tires on the trailer. Then turn the cold roll (spring shaft) toward the front of the trailer until the cold roll clip is against the inside of the "U" shaped bend in the spring. Place a pipe wrench between the arm connector and the flange bearing, and turn the spring shaft toward the front of the trailer five to six hours to put tension on the front spring.

With the shaft held at this position, weld the arm connector to the spring shaft. Next, raise the arms to the top rear of the trailer and insert the end of the crossover into the top end of each of the arms and fasten together using 5/16" bolts, nuts and washers.

4B:

Connecting back-up arm and connector. After the arms have been connected to the front spring shaft and the crossover has been installed, the next step is to install the back-up arm system. Slide the back-up arm connector onto the rear spring shaft, then weld the loose end of the chain on the back-up arm to the main arm, *see figure 6a*. Next rotate the back-up arm connector on the shaft until the chain is strait then apply three to four hours of tension to the back-up arm using the same method as on the main arm.

Tarp Installation and Wiring Diagrams are located on pages 9 and 10.