

MOUNTAIN TARP

www.mountaintarp.com A WASTEQUIP COMPANY

800-248-7717



Tarp-N-Go Systems Installation Instructions

**P.O. Box 186
1002 North 15th Street
Middlesboro, Kentucky 40965**

**Phone: 800-248-7717
Fax: 606-248-2077
E-mail: sales@mountaintarp.com**

Contact your local Mountain Tarp Dealer for parts and service

Congratulations on your purchase of a Mountain Tarp Tarp-N-Go system. We promise that all our tarp systems are built from the highest quality material available, therefore we can also vow to stand behind our product. No matter how long you search you will not find a better built tarp system than you can get right here in the mountains of Southeastern Kentucky.

WARNING:

- Always uncover load completely before dumping. Never dump with load covered.
- Failure to uncover load completely before dumping may cause damage to the system.
- Do not over-tighten the system. This may damage the system or cause it to function improperly.

CAUTION:

- Read through instructions for entire system and follow directions thoroughly to ensure system functions properly.

MAINTENANCE:

- Check tension on cables
- Clean and lubricate cables with penetrating oil (example: WD-40)
- To clean and lubricate the cables, simply wipe with a penetrating oil dampened rag. Spray the bow ends with penetrating oil, but DO NOT use heavy oils or grease. This will cause dirt to stick to the cables.

NOTES:

- The longevity of the Tarp-N-Go system can be greatly increased by leaving the system in a “covered load” position, with tension on the tarp, at all times except while loading or dumping. This will also eliminate tailgate drag when traveling empty.
- The system has proper cable tension when you cannot easily touch the cables together when squeezing with one hand 18” from the rear pulley.
- To apply tension to the cables, loosen the mounting nut on rear pulley assembly, then tighten the nut on the tension bolt at the rear of the pulley assembly. To relieve tension, loosen the nut on the tension bolt.

TOOLS REQUIRED:

- | | |
|--|----------------------------|
| • Ratchet | • Drill |
| • 3/8”, 1/2”, 9/16”, and 3/4” Sockets and Wrenches | • 3/8” and 1/2” Drill Bits |
| • Pipe Wrench | • 1-1/2” Hole Saw |
| • Welder– Steel and Aluminum | • Snap Clamps |
| • Screw Driver | |

SYSTEM CONTENTS:

- | | |
|------------------------------------|-----------------|
| (1) Front Pulley Assembly | (1) Tarp |
| (2) Rear Idler Assemblies | (1) Wind Shield |
| (1) Motor or Crank Assembly | (1) Tension Bar |
| (1) Sprocket Chain (Manual) | Anti Lifts |
| Electrical Components (wire, etc.) | Tarp Keepers |
| Bows (Flat, 6”, or 12”) | |

Installation Table of Contents

Step 1: Front Pulley	2-3	Step 6: Wind Shield	8
Step 2: Motor or Crank Assembly	4	Step 7: Ramp	9
Step 3: Electrical Wiring and Components	5-6	Step 8: Tightening Tarp-N-Go	9
Step 4: Rear Idler Assembly	7	Step 9: Anti-Lift	10
Step 5: Cable, Tarp, and Bow	8	Parts List	11

Tarp-N-Go System Installation

Step 1: Front Pulley Installation

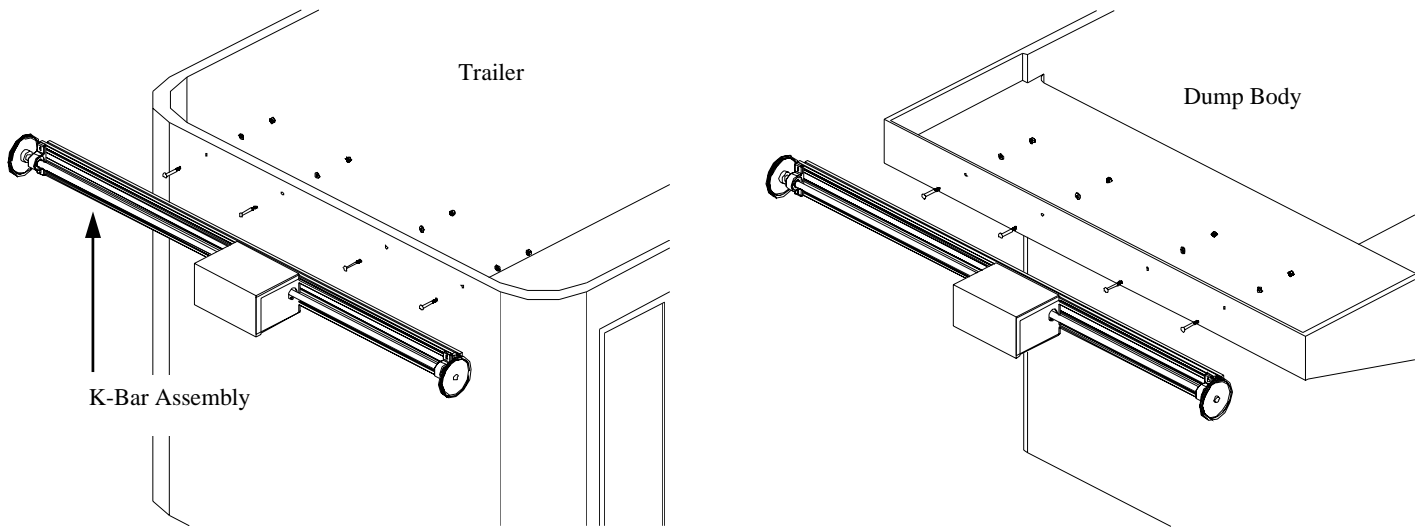

Figure 1

1A:
Before beginning installation, check the top rail of the body or trailer, or the top of the side boards if present, to make sure that both sides have an even plane for the bows to ride on. If there is damage or any other obstruction on the top surface, it may be necessary to repair it or fabricate a surface for the bows to ride on.

1B:
Installing the K-Bar Assembly (Outside Mount), see figure 1. First, measure in 18" from outside of the top rail or cab protector, then measure down 2-1/2" from the top of the top rail or other surface where the bows will be riding and make a mark at this point on each side of the body or trailer (note: if the cab protector or bulkhead is raised, the system should be mounted 2-1/2" below the top of the side walls or top rail or other surface where the bows will be riding, see figure 1a).

Next find the center point of the bulkhead or cab protector and measure out 10" to 14" on each side of the center point then down 2-1/2" from the top and make a mark at each of these two points. Using a 1/2" drill bit, drill a hole at each of these four marks. Finally, using 1/2" x 4-1/2" carriage bolts, 1/2" flat washers, and 1/2" nuts secure the K-Bar to the bulkhead (note: the carriage bolts slide into a slot at the rear of the K-Bar. Once they are inserted into the slot they can be moved to line up with the previously drilled mounting holes in the bulkhead or the cab protector, see figure 1b).

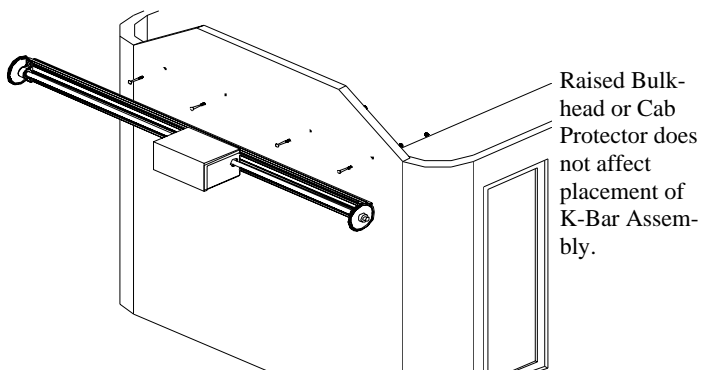

Figure 1a

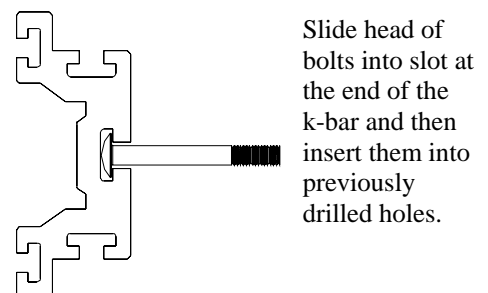

Figure 1b

Tarp-N-Go System Installation

Step 1: Front Pulley Installation Cont.

1C:

Installing the pulley shaft assembly (Inside Mount), see figure 2. The inside mount may be used if you are prevented from using the outside mount (example: the inside mount is appropriate for dump bodies with offset cab protectors. This option may also be desired for dump bodies with full cab protectors for cosmetic purposes, see figure 2a).

The first step for this installation is to determine the placement of the pulley assembly. To do this, measure four inches toward the rear of the body from the front of the front post or cab protector (note: if a corner radius is present, start your measurement at the rear most point of the radius). Then measure down from the top of the top rail or cab protector 2-1/2" and make a mark at the intersection of these two measurements, see figure 2b. Using a 1-1/2" hole saw, cut a hole in the bulkhead or cab protector, then follow the same steps for the opposite side of the body.

Next, insert the pulley shaft into the previously cut holes on each side of the body or trailer and slide a flange bearing onto the end of the shaft on each side. Then, adjust the shaft so that it is level and square with the body and in the center of the previously cut holes, then place the bearings flush against the side wall and using a 3/8" drill bit, drill holes in the wall to match the mounting holes in the bearings. Then, using 3/8" x 1-1/2" bolts, 3/8" washers and 3/8" nuts, secure the bearings to the body or trailer. (note: for electric systems on dump bodies or other applications where the motor will be mounted at the center of the pulley shaft it will be necessary to slide the sprocket onto and to the center of the shaft before inserting the shaft into the bearing holes. For manual systems, the sprocket should be installed on the outside of the pulley).

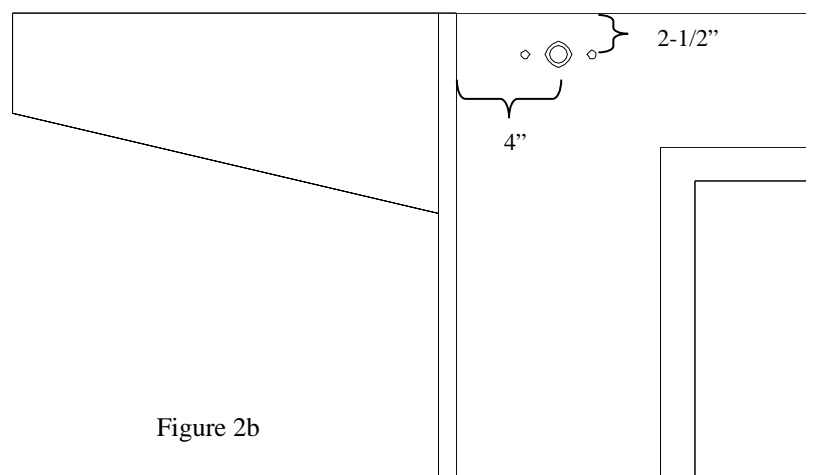
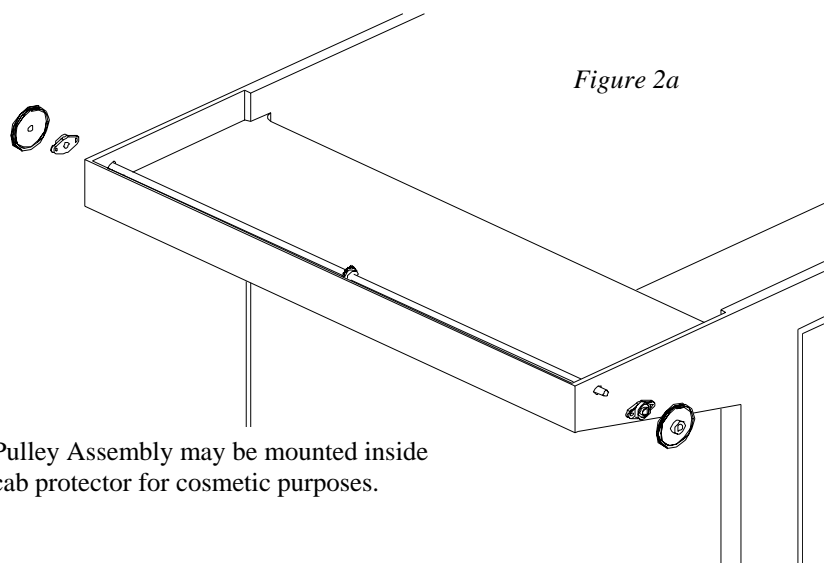
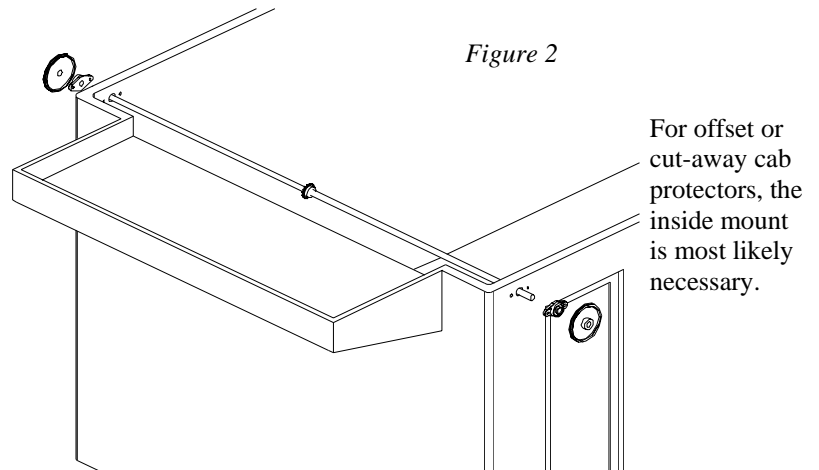

Tarp-N-Go System Installation

Step 2: Motor or Crank Assembly Installation

2A:
Installing the motor for electric systems, see figure 3. For outside mounts the motor comes pre-assembled and mounted to the K-Bar assembly. Therefore, installation is not required for this application. For inside mounts, however, the motor is mounted on a bracket inside the cab protector. First, fasten the motor to the mounting bracket provided sliding the bolts to the very front of the slots in the bracket. Then, place the motor at a point on the cab protector so that the sprocket on the motor lines up directly with the sprocket on the pulley shaft. Hold the motor in this position and weld the bracket to the cab protector. Next, install the sprocket chain by wrapping the chain around the sprocket on the motor, and then around the sprocket on the pulley shaft. Bring the two ends together and mark the chain at the desired length. Cut and discard the excess chain and fasten together with the master link provided. Finally, loosen the mounting bolts on the motor, pull the motor toward the front of the cab protector to tighten the chain, then retighten the mounting bolts.

2B:
Installing the crank assembly for manual systems, see figure 3a. After completing installation of the front pulley assembly the next step is to install the crank assembly. For manual systems, the crank assembly is mounted to the bulkhead or front post near the bottom of the trailer or body where it can be easily reached from the ground. For dump bodies and trailers with little or no corner radius the assembly may be mounted directly to the front post or the side of the bulkhead. However, if a corner radius is present then the assembly may be mounted to the bottom rail or flush mount fender (note: it may be necessary to fabricate a mount if no flush mount fender is present).

After determining the proper placement, hold the assembly in place and make a mark on the body or trailer at the bottom of each of the four mounting slots in the spider wheel. Next, using a 3/8" drill bit, drill holes at these marks. Then, using 3/8" x 1-1/2" hex bolts, mount the assembly to the body or trailer with the mounting bolt at the bottom of the slots in the spider wheel but do not completely tighten bolts. The next step is to install the sprocket chain. First, wrap the chain around the sprocket at the end of the pulley assembly and then around the sprocket on the crank assembly. Bring the ends together and mark the chain at the desired length. Cut and discard the excess chain and fasten the ends with the master link provided. With the chain in place, loosen the bolts on the spider wheel and pull down on the crank assembly to tighten the chain, then re-tighten the bolts to secure the assembly to the body or trailer.

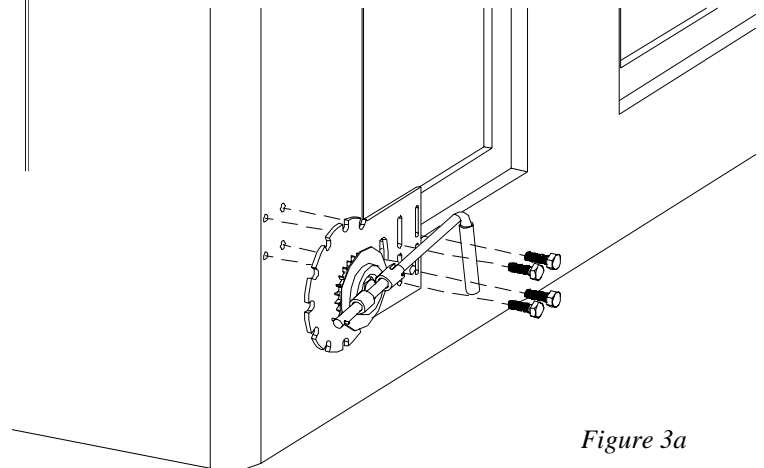
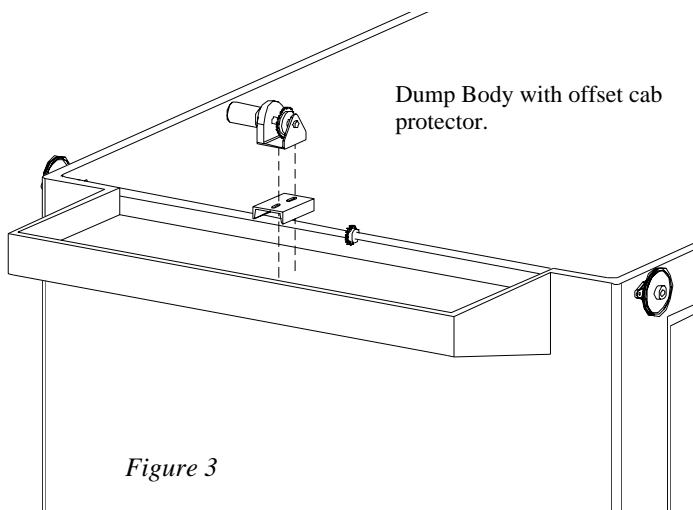

Tarp-N-Go System Installation

Step 3: Electrical Wiring and Components Installation

3A:

Installing the electric system from the motor to the disconnect for framed trailers, see figure 4. For framed trailers, begin by installing the contact pad (note: contact pads are necessary on some trailers to prevent line loss. They may not be necessary for some shorter framed trailers). Find a spot on the trailer, near the front, where the pads can be mounted and not interfere with the dumping process yet make good contact when the trailer body is down. After finding the proper location, clean the surface on both the frame and the trailer body where the pads will be mounted.

With the body completely lowered, clamp the pads in place using vice grips or c-clamps. The pad with the steel base should be mounted to the frame, and the pad with the aluminum base should be mounted to the trailer body, see figure 4a (note: when the body is completely lowered, the heads of both copper bolts on the pad mounted to the frame should make contact with the copper portion of the pad mounted to the trailer body. The pads may be mounted either horizontally or vertically to achieve this connection).

With the pads clamped in this position, weld the pads in place. (note: to adjust contact, loosen or tighten the spring bolts on the pad mounted to the frame). After the contact pads are in place, the next step is running the wire. Start by connecting the motor to the contact pad mounted to the trailer body. First connect the wires to the motor, see figure 4, then run the wire directly to the bulkhead or into the machined channel in the K-Bar. Next, according to preference, either run the wire directly down the center of the bulkhead to the bottom and under the trailer to the front of the frame where existing wire disconnects are located, or run the wire into the machined channel in the K-Bar and toward the top left corner of the trailer. Then using a 1-1/4" hole saw cut one hole in the top left corner and, if needed, one underneath the bottom left corner of the bulkhead.

Thread the wire, first, through a rubber grommet, then into the hole at the top of the bulkhead, down through the channel in the corner of the bulkhead, and back out through the hole underneath the bottom corner. From there, run the wire toward the front of the frame where existing wire disconnects are located. Next, if one is not available, cut a hole for the disconnect assembly near existing disconnects. Then, connect the wire to the female end of the disconnect provided.

3B:

Installing the electric system from the motor to the disconnect for frameless trailers, see figure 4. For frameless trailers, first, connect the wire to the motor then run the wire into the machined channel in the K-Bar and toward the top left corner of the trailer. Then, using a 1-1/4" hole saw, cut one hole in the top left corner of the front of the trailer, and if needed, one underneath the bottom left corner. Thread the wire, first, through a rubber grommet, then into the hole at the top of the trailer, down through the channel in the corner of the trailer, and back out through the hole underneath the bottom corner. From there, run the wire toward the front of the trailer where existing wire disconnects are located. Next, if one is not available, cut a hole for the disconnect assembly near existing disconnects. Then, connect the wire to the female end of the disconnect provided.

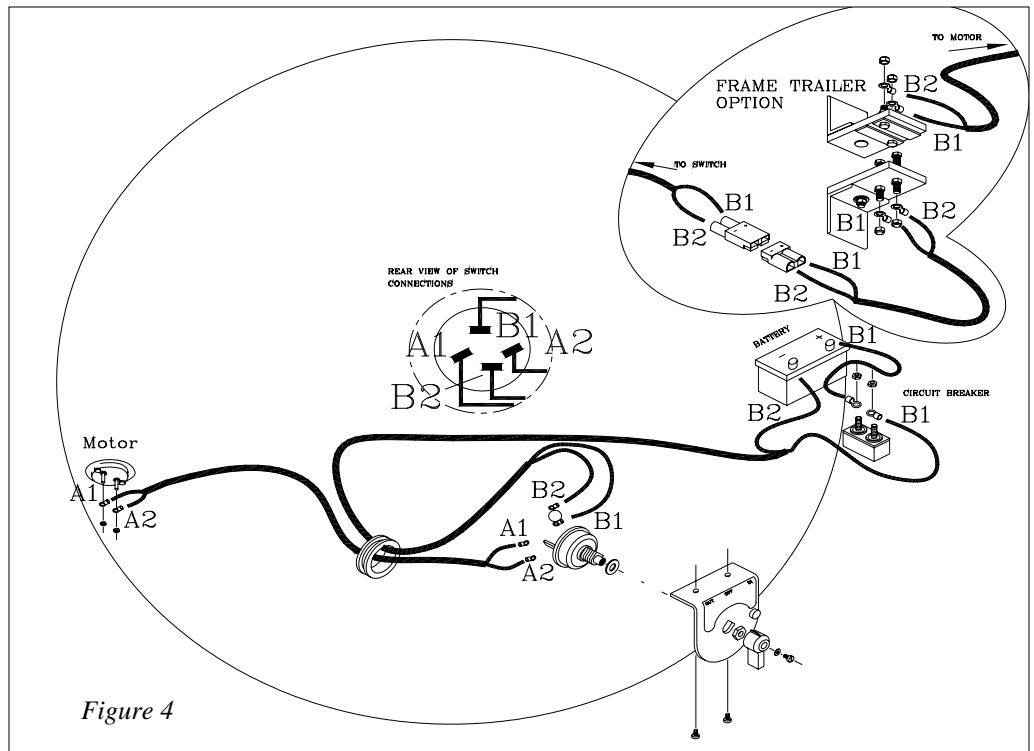

Figure 4

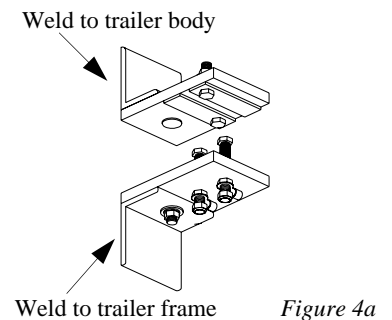

Figure 4a

Tarp-N-Go System Installation

Step 3: Electrical Wiring and Components Installation Cont.

3C:

Installing the electric system from the motor to the cab for dump bodies, see figure 4. First, connect the wire to the motor, then, for inside mounts, run the wire along the inside front of the cab protector to the left side and then along the inside left to the rear of the cab protector. For outside mounts, after connecting the wire to the motor, run the wire into the machined channel in the K-Bar and toward the left side of the cab protector. From there, either run the wire up over the top and to the inside of the cab protector, or run the wire along the outside and to the rear of the cab protector. With the wire at the rear of the cab protector, either run the wire along the outside of the front left corner of the body toward the bottom, or cut one hole in the top left corner and one underneath the bottom left corner and run the wire through the channel inside the body toward the bottom of the body. With the wire at the bottom left corner of the body, run the wire, following existing wires, toward the rear of the body. Run the wire to the hinge point of the body, around the hinge, and back toward the front of the body along the frame of the truck, continuing to follow existing wires. Continue along the frame to the rear of the cab.

3D:

Installing the cab control portion of the electrical system, see figure 4. First, install the switch assembly at a convenient and accessible place inside the cab. Next, for trailers, connect the wire to the male end of the disconnect provided and follow existing wires to the rear of the cab. From there, for both trailers and dump bodies, run the wire into the cab following existing wires and connect to the switch assembly. Finally, connect wire to the remaining post on the switch assembly and run toward the battery following existing wires when possible. Then, connect the wire either directly to the battery or to an existing positive and negative wire already connected to the battery.

NEW Wiring Diagram for Rocker Switch

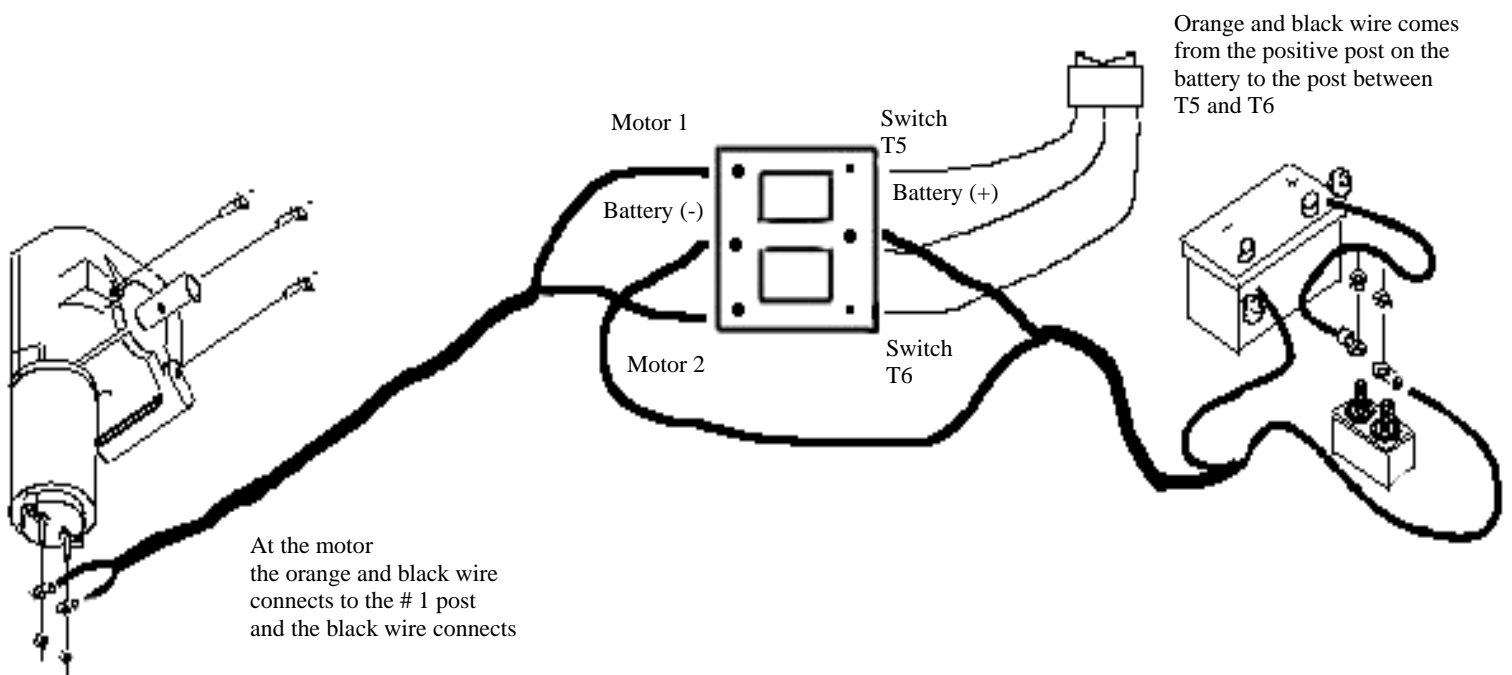

Tarp-N-Go System Installation

Step 4: Rear Idler Assembly Installation

4A:
Installing the Rear Idler Assemblies, see figure 5. The first step to installing the rear idler assembly is determining their placement. This is influenced by the tailgate style present on the body or trailer. If the body or trailer has a swing style tailgate, the rear of the idler plate should be placed at or in front of the rear of the body or trailer, not the tailgate, so that when opened, the tailgate does not make contact with the idler assembly. If the existing tailgate is not a swing style tailgate, the assembly should be installed as far back as possible, however, there must be enough of the idler plate in contact with the body or trailer to get at least four bolts into the assembly, see figure 5a. To determine where to place the assembly relative to the top of the body or trailer, simply place the assembly so that the top of the idler plate is flush with the top of the top rail or other structure on which the bows will be riding.

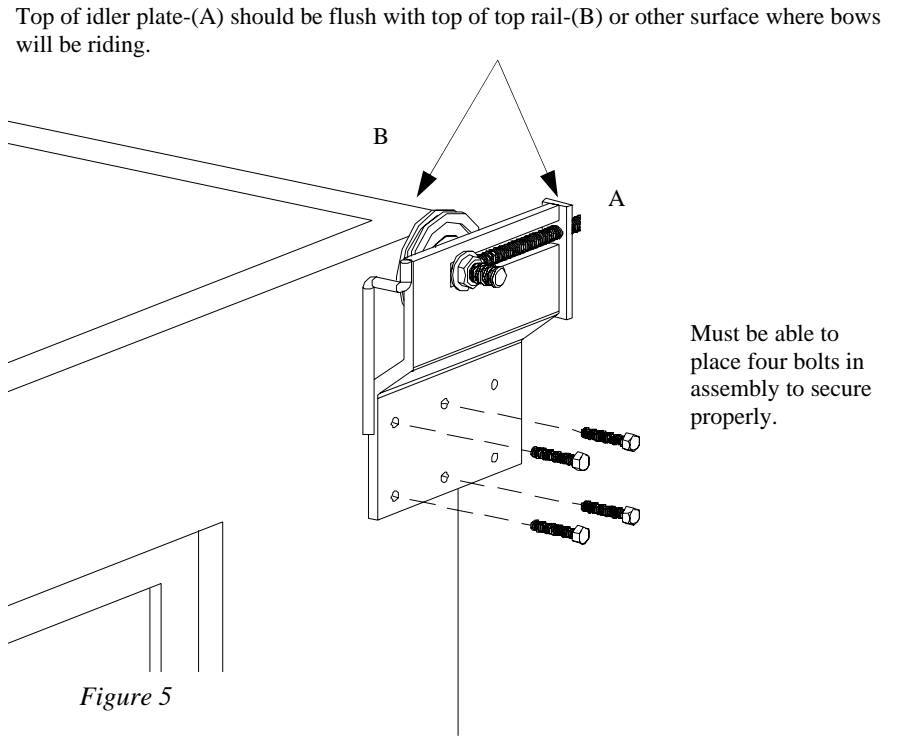

After determining the location of the assembly, using 3/8" x 1-1/2" machine bolts and 3/8" flat washers, fasten the assembly to the top rail (note: if it is necessary for the tarp to extend further beyond the tailgate than is achieved with the standard idler assembly, this extension can be achieved with the extended rear idler assembly "optional"). The next step, when installing the idler assembly on the opposite side, is to be sure the distance between the front and rear assemblies is the same on each side. To do this, measure from the center of the front pulley to the front of the rear idler, then install the assembly on the opposite side so that these distances are exactly the same. After installing both rear idler assemblies, it is necessary to be sure the system is square. For the system to be square, the measurements from the right front corner to the left rear corner must be the same as the measurement from the left front corner to the right rear corner (note: the distance between the rear idlers must be the same as the distance between the front pulleys. It may be necessary to use shims to achieve these distances).

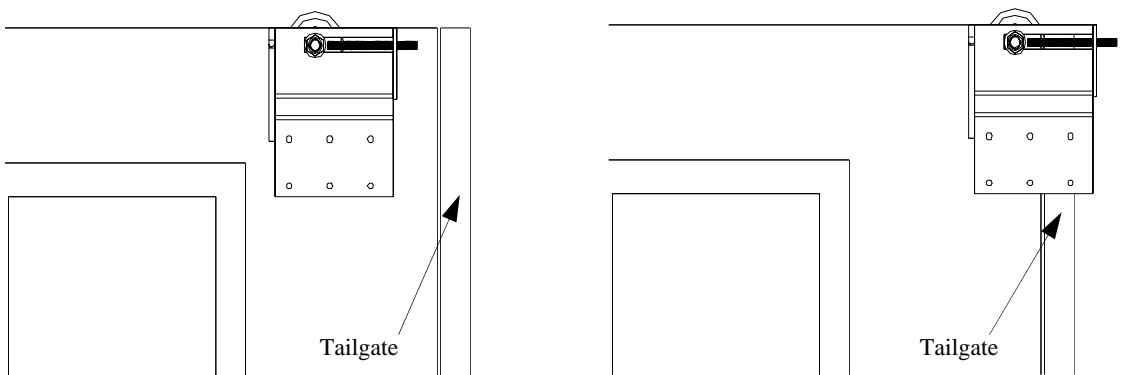

Swing style tailgate: Idler assembly is moved forward to prevent interference with the opening process.

No Swing style tailgate: Idler assembly is placed as far back as possible.

Figure 5a

Tarp-N-Go System Installation

Step 5: Cable, Tarp, and Bow Installation

5A:
Installing the Cables, Bows and the Tarp, see figure 6 (note: the tarp and bows come pre-assembled and held together by shipping rods, therefore, this step is already completed). First, set the tarp and bow assembly on the front of the body or trailer with shipping rods still in place. On the driver side of the body or trailer, thread the cable down around the rear idler and toward the front of the body or trailer. Next, remove the shipping rod from the driver side only. Thread the cable up around the front pulley and then through the holes at the end of the bows starting with the front bow going rearward. After threading through the bows, stop with two to four inches of cable protruding from the last bow. Next, bring the other end of the cable forward to meet the previous end at the last bow. Using two cable clamps, clamp the ends together placing one clamp in front of and one clamp behind the last bow, see figure 6a. Next, test the system by running it back and forth to be sure of proper function. It may be necessary to tighten or loosen one side of the system or the other to achieve proper system function. Lastly, when assured the system is functioning properly, cut the excess cable and tape the ends. Repeat these steps for the opposite side of the body or trailer.

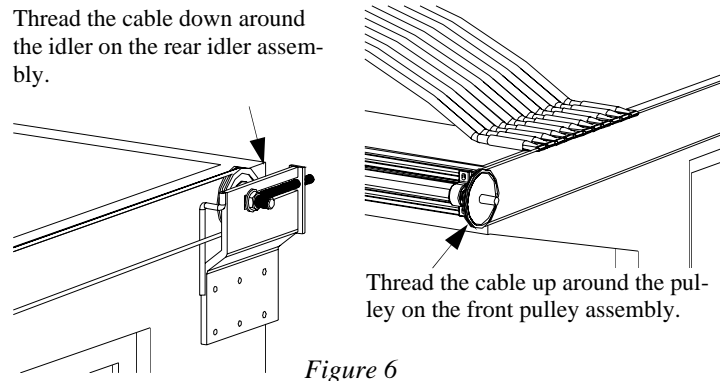

5B:
Tightening the cables, see figure 6b. To tighten cables, loosen the sheave nut on the pulley bolt then tighten the nut on the tension bolt until cable is taught (note: the tension on each side of the system needs to be nearly the same.)

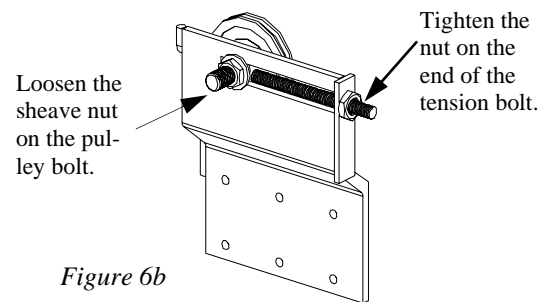
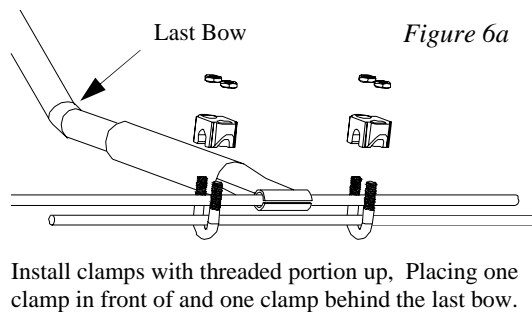

Step 6: Wind Shield Installation

6A:
Installing the wind shield. Wind shield placement is dependant upon the type of system mount. For outside mounts, the wind shield is mounted to the top of the K-Bar, see figure 7. For inside mounts, the wind shield is mounted on top of the front of the cab protector, see figure 7a. If mounting the wind shield to the top of the K-Bar, slide the carriage bolts provided into the top slot at the end of the K-Bar and move them to the desired position and drill matching holes in the

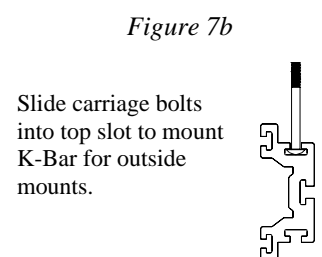
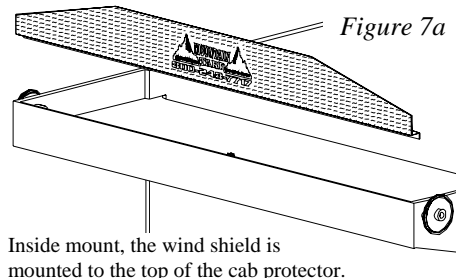
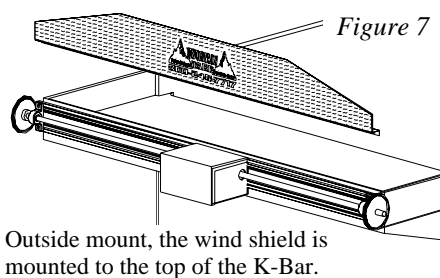

Tarp-N-Go System Installation

Step 7: Ramp Installation (Optional)

7A:

Installing ramp for radius bulkheads (optional). To install ramps for trailers with flat top rails, see figure 8, place the front of the ramp against the K-Bar with the horizontal portion of the ramp resting on top of the top rail. Mark the ramp along the contour of the radius of the bulkhead. Cut the ramp along this mark and cut off any excess metal leaving at least 6" of the vertical portion of the angle in contact with the side wall of the trailer.

Install the ramp by either bolting or welding it to the side of the trailer. Then fasten the front end of the ramp to the K-Bar by sliding a carriage bolt into the slot at the end of the K-Bar and inserting it into the hole at the end of the ramp. For trailers with an inverted angle top rail, measure from the K-Bar to the end of the angle on the top rail. Cut the inverted angle ramp, see figure 8a, to this length and weld it on top of the top rail so that the rail continues on toward the K-Bar (note: ramps are only necessary if the radius present is greater than 6").

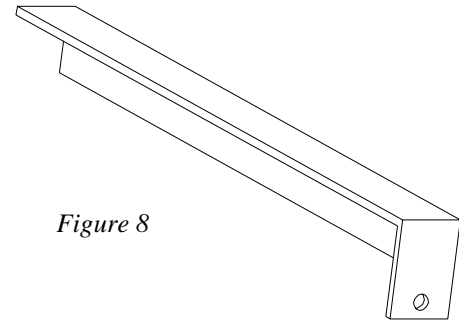

Figure 8

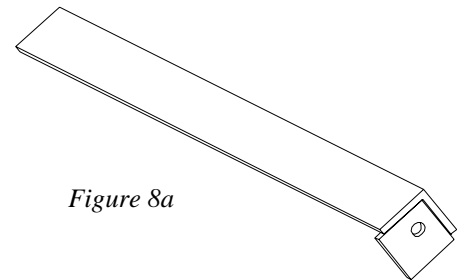

Figure 8a

Step 8: Tightening the Tarp-N-Go System

8A:

Putting tension on the system, see figure 9. To tighten the system, start by running the tarp toward the covered load position and stopping with the last bow three to four inches from the rear idlers. Next, fasten the front end of the tarp to the tension bar with the tek screws provided (note: in most instances the tarp comes with the tension bar attached, therefore this step may already be completed). Then, roll the tension bar in the direction that rolls the tarp onto the top of the tension bar, see figure 9a. Roll the bar until the tarp is taught then mount the tension bar and tarp on top of the mounting flange of the wind shield. If a wind shield is not being used, mount the tension bar on top of the K-Bar, see figure 9b.

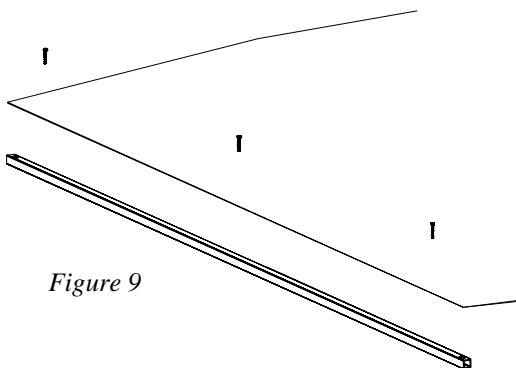
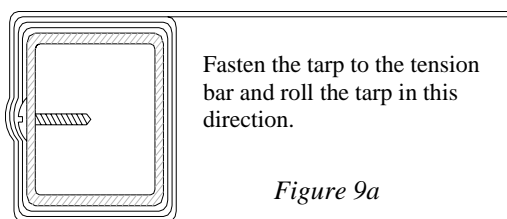

Figure 9



Fasten the tarp to the tension bar and roll the tarp in this direction.

Figure 9a

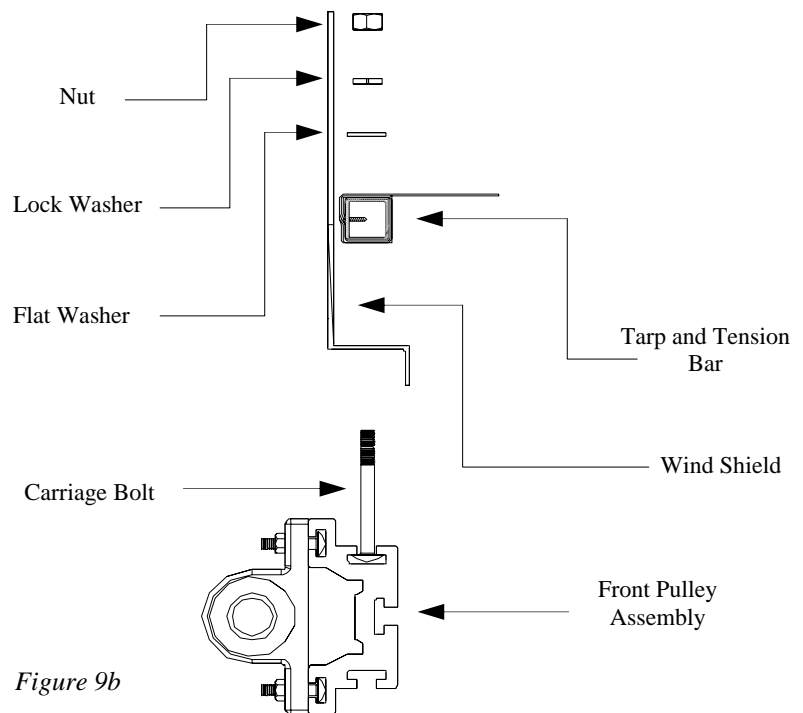

Figure 9b

Tarp-N-Go System Installation

Step 9: Anti-Lift Installation

9A:

Installing the Anti Lifts, see figure 10, (notes: the anti lifts are installed to prevent the tarp from gaining lift due to air flow under the tarp. The number of anti lifts used is determined by the length of the system. Longer systems require more anti lifts, shorter systems require less. Anti lifts should be spaced evenly on bows). After determining the particular bows that will hold the anti lifts, the next step is to secure the anti lifts to the bows. The longest anti lift should be in front with the shortest anti lift at the rear.

To secure the anti lift to the bow, place the anti lift on top of the flat end of the bow so that the hole in the anti lift matches the hole at the end of the bow. Then with the horizontal catch bar facing toward the rear of the body or trailer, insert the 1/4" hex bolt up through the holes and slide the washers onto the bolt starting with the 3/8" washer, then the 1/4" washer. Then fasten firmly using the lock nuts provided, see figure 10a. The next step is to install the bolt assembly. After installing the anti lift, measure one half inch up and over from the inside corner of the anti lift and make a mark at this point on the side wall of the body or trailer. Then using a 1/2" drill bit, drill a hole at this mark. Finally, slide the anti lift washer and then the spacer onto the 1/2" x 7" bolt and insert the bolt into the previously drilled hole and then firmly secure the assembly using the 1/2" washers and 1/2" hex nuts provided, see figure 10b.

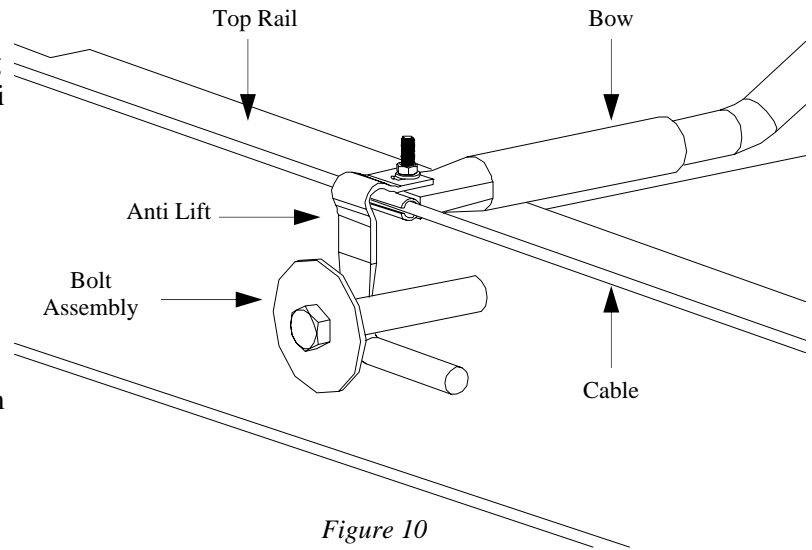
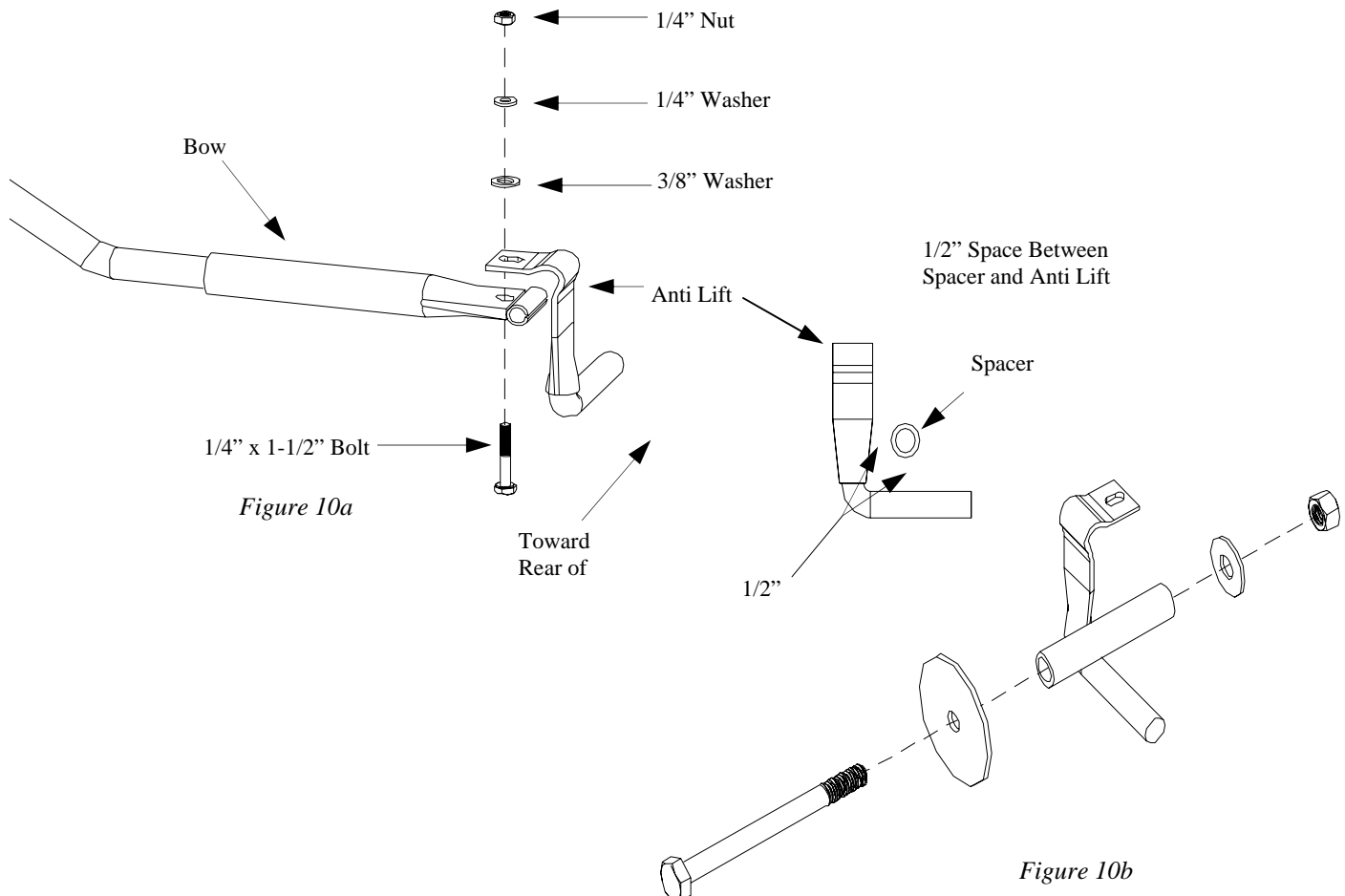
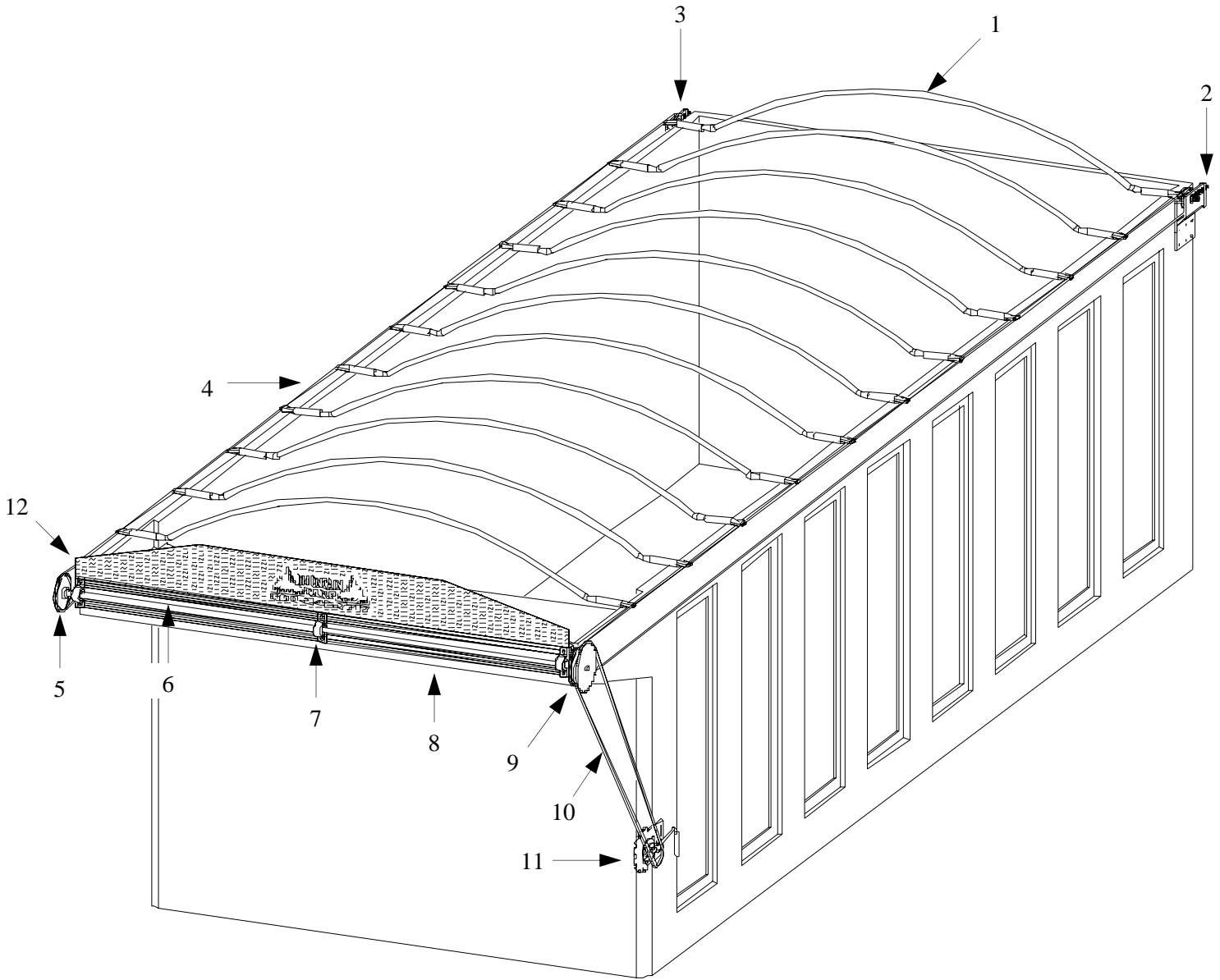

Figure 10



Tarp-N-Go System Installation



Des. #	Description	Part #	Des. #	Description	Part #
1	Bow-98" With 12" Rise	Z5001K	7	Pillow Block Bearing	K0520
2	Rear Pulley Assembly (Left)	Z7000K	8	K-Bar (95")	Z1017
3	Rear Pulley Assembly (Right)	Z7001K	9	9" Sprocket	Z1002
4	Stainless Steel Cable (per foot)	Z1014	10	# 40 Sprocket Chain (per foot)	Z2007
5	7" Pulley	Z1001	11	Crank Assembly	Z1013C
6	Pulley Shaft (99-1/2")	Z1004	12	95" Wind Shield	Z1009